

HOLYKELL

Ultrasonic Flow and Level Meter Operate Manual (Open Channel Flow Meter)

I. The HOLYKELL's UFL9000 and UFL8000 ultrasonic flow and level Meter, with full English menu, for easy setup, you can meet different needs. Under normal circumstances, according to the instructions of the installation requirements, installed equipment, just need to set the following parameters, the device can be used normally.

There are three buttons on the panel by which you can debug the instrument. After debugging, the LCD screen can display measured values.



- ◇Enter the menu
- ◇Confirm the menu item
- ◇Confirm the parameters modify

- ◇Moving the cursor
- ◇Select menu item
- ◇Parameters modify

- (1) Offer power to meter and meter is displayed; press the set button (SET) two seconds to enter level 1 menu.
- (2) Input the height values of the probe to the "reference zero", and the location of "reference zero" in the menu is shown in attached appendix table2 menu Structure.
- (3) Setting "4mA flow value" and "20mA flow value"
 4mA flow value: when moment flow is equal to the set value, the device output 4mA.
 20mA flow value: when moment flow is equal to the set value, the device output 20mA.
 "4mA flow value" and "20mA flow value" are shown in attached appendix table2 menu Structure files.
- (4) How to choose the type of measuring flume for measurement, it should consider flow of channel, current state of channel, considering whether the current is a free flow. If the maximum flow is less than 40l/s (144t/h) we suggest to use right triangle weir; if flow is greater than 40l/s we suggest to use parshall flume; if the upstream channel is short, and the maximum flow is greater than 40l/s we suggest to use rectangular weir. Before using device for measurement we first need to calibrate the reference point, it is a distance from Transducer to water level zero point of weirs. **(The meter's defaulting choice is parshall flume)**

① Right Triangle Weir

In order to use right triangle weir, we can start from menu "10 weir type" → "right triangle weir" then set it "open", if meter has installed a water-flow meter, flow velocity can be directly come out according to water level value.

② Rectangular Weir

In order to use rectangular weir, we can start from menu "10 weir type" → "rectangular weir" then choose "0.25m, 0.50m, 0.75m, 1.00m", if meter has installed a water-flow meter, flow velocity can be directly come out according to water level value.

③ Parshall Flume

In order to use parshall flume, we can start from menu "10 weir type" → "parshall flume" then set it "open", the flow formula of parshall flume is: $Q=Ca^n$. According to larynx way "b", find out repair work coefficient c and index n from appendix table2, input them into menu "9 set constant" → "1 repair work coefficient c" and "index n", then meter can calculate the corresponding velocity of water level automatically.

Suggestion: If you connect the ultrasonic open channel flow meter to inverter, PLC, etc interference devices, you'd better add an isolator between them. Ultrasonic open channel flow meter can't share same power with inverter, PLC, etc interference device.

Instruction manual of ultrasonic open channel flow meter

I . Introduction

Ultrasonic open channel flow meter is used together with weir trough, to measure water flow of open channel. Mainly makes application for measuring wastewater treatment plant, enterprises and institutions' sewage outfalls, city sewer's flow and farmland irrigation channels, etc.

As our company's meter using ultrasonic through air, is a non-contact measurement method. So in sticky corrupt, corrosive liquid cases, it has higher reliability than other forms of meter.

II. Main Technical parameters

Function	Split Type
Measure range	0.1l/s~99999.99m ³ /h
Total flow	4290000000.00m ³
Level measurement precision	0.25%F.S. to 0.5%F.S.
resolution	3mm or 0.1%F.S. (take great)
Flow measurement precision	1%~5% (depends on poling board type and weir's precision)
display	English backlit LCD: moment flow, accumulative flow, level measurement value, distance measurement value, analog value, environment temperature, echo state, alarm display, algorithm select, etc.
Analog output	4~20mA/750Ω load
Relay output	4 channels AC 250V/ 8A or DC 30V/ 5A state programmable
Power supply	220V AC±15% 50Hz 24VDC 120mA can be customized 12VDC power supply
Environment temperature	Display meter-20~+60℃, Transducer-20~+80℃
communication	RS485, RS232communication, MODBUS protocol (optional)
Protection grade	Display IP65, Transducer IP68
Transducer cable	Max is 100 meters, with standard 10 meters
Transducer installation	Threaded installation, flange installation, stents installation, instrument cases installation, etc

Note: This series of ultrasonic open channel flow meter's Transducer also can customize according to customer's demand: resistance to high pressure and high temperature, small-bore, small blind area, and other special specification.

III. Installation Guide

1. Installation of open channel flow meter

◆ Appearance image and size figure of split type open channel flow meter's display instrument

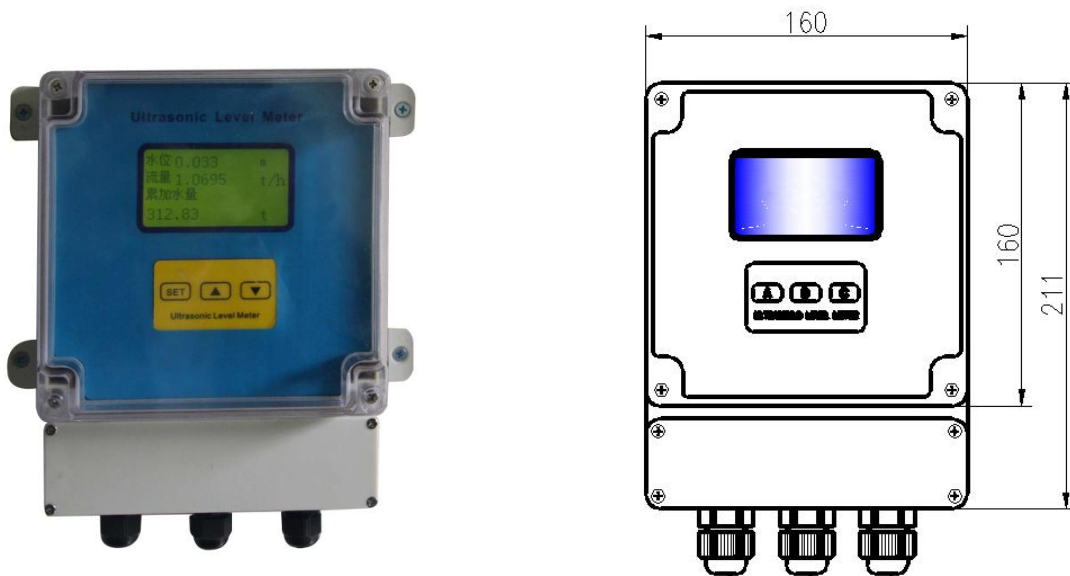

4

Flow meter's display instrument should be installed in indoor. And the indoor require being good ventilation, no corrosive gas. Meter is handing installation. If the indoor condition is bad, or meter must be hand outdoor, then the meter should be installed in meter protective case, avoid weathered.

◆ Appearance image and size figure of integrated type open channel flow meter



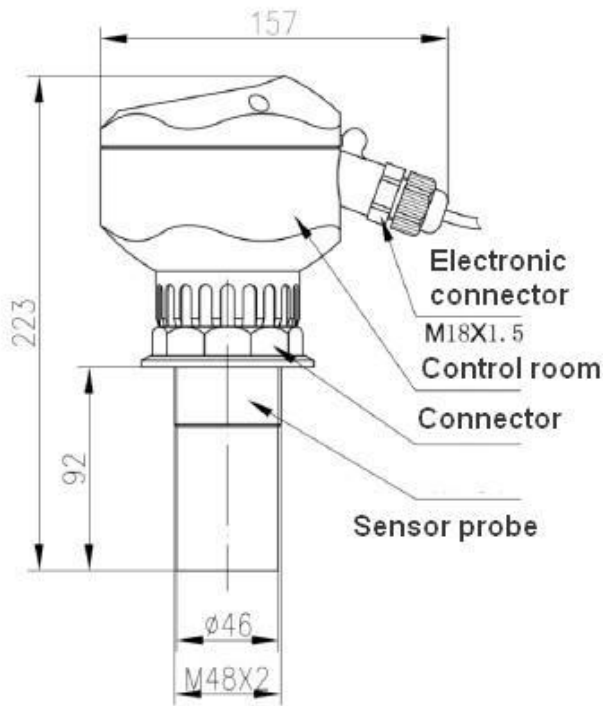

Sensor mounting size: M48*2.0 male thread

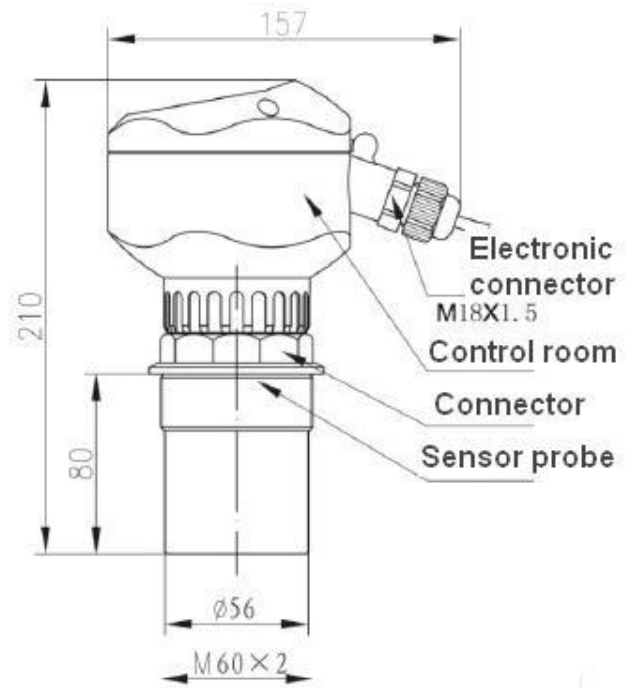

Sensor mounting size: M60*2.0 male

IV. Flowmeter Installation

4.1 Transducer Installation

Ultrasonic open channel flow meter's Transducer can be directly installed above the water level observation of measuring flume. Voice side of Transducer should be on the surface. We can put a level on the upper cover of Transducer, through calibrating the upper cover so that the Transducer is alignment to surface. Parshall flume's water level observation is on the 2/3 contraction of throat.(As shown in figure 8.4's la); triangle weir and rectangular weir both on one side of upstream, from poling board 3~4 times greater than the weir deep. (As shown in figure 5.2.1)

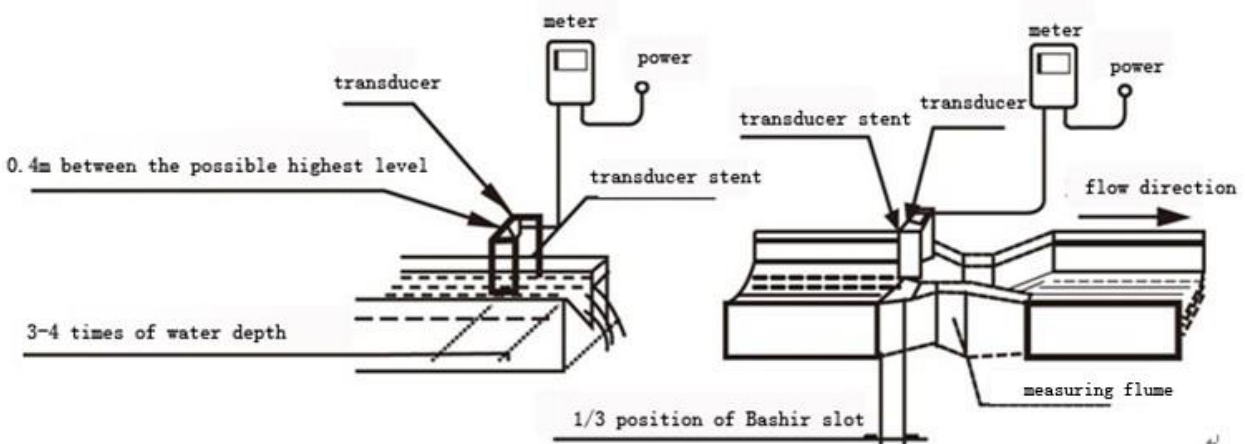





triangular weir and rectangular weir local pictures



Parshall flume local installation pictures

4.2 Measuring flume's installation

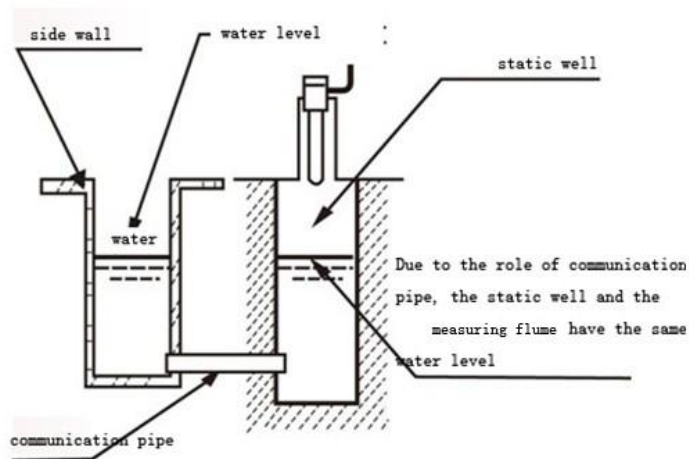

- ①. Measuring flume's centerline must coincidence with channel's centerline, which makes water into measuring flume doesn't appear flow deviation.
- ②. After measuring flume is watered, the water flow pattern should be free flow. The downstream water level of triangle weir and rectangular weir should be lower than the camp weir (as shown in right figure); parshall flume's submergence degree should be less than the critical submergence degree of "parshall groove parameters" (as shown in below figure)
- ③. There must exist a straight section on the upstream of measuring flume which is more than 5 times wide to channel, let the water come into measuring flume smoothly, no deviation, no momentum that formed from channel rail.
- ④. Measuring flume be firmly installed on the channel. Linking closely to the channel wall, channel bottom, can't slack. Let the water flows completely through the measurement of measuring flume. The measurement part of measuring weir plant is weir's mouth; the measurement part of measuring flume is the throat section in weir.

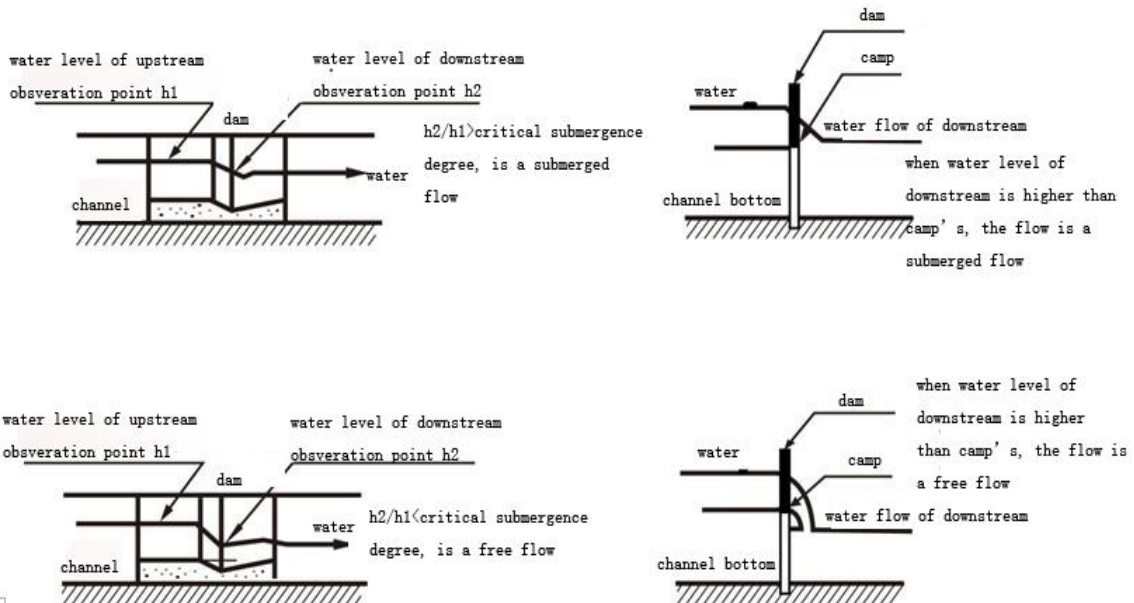
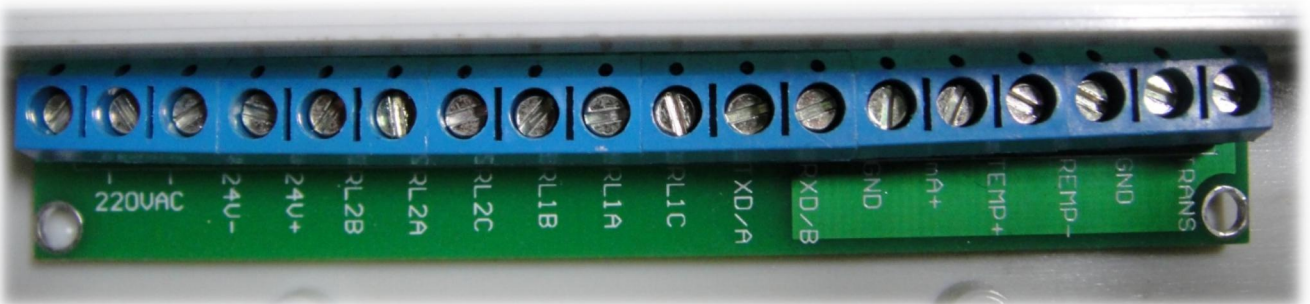

Figure 5.3.1、Static Well

4.3 Electronic Wires Connection

◆Terminals real figure and schemes of split type open channel flow meter



UFL9000 Terminal Box

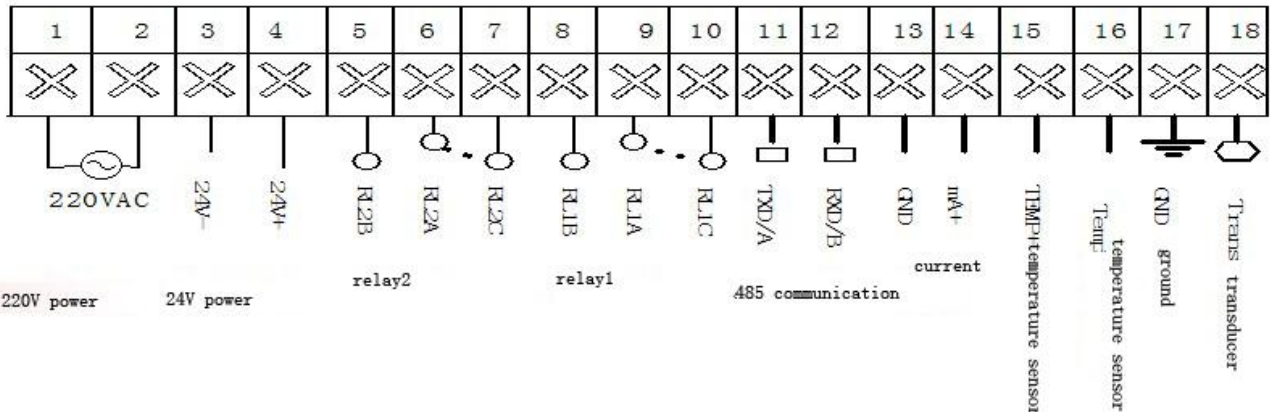

Wires Connections:

Transducer (Trans): Red wire---connected Transducers by factory before shipment.

GND (Shield wire): Yellow wire---connect with ground wires.

Temp+: Blue wire---connect with temp output+.

Temp-: Black wire---connect with temp output-.

Current output: output current + / mA+; output current- connect with GND.

Relay: RLnA and RLnB normally are open; RLnA and RLnC normally are close.
(When single Transducer, then n = 1, 2)

Power supply: If supply is 220V AC, Then power wires connect with L and N.
If power supply is 24 V DC, Then 24V + connect with 24V+ and 24V- connect with GND.

(2) Integrative type ultrasonic volumetric meter Electrical connection:

- ◆ **Integrative type diagram of Open channel flowmeter terminals**
24VDC, 220VAC power supply terminal block diagram:

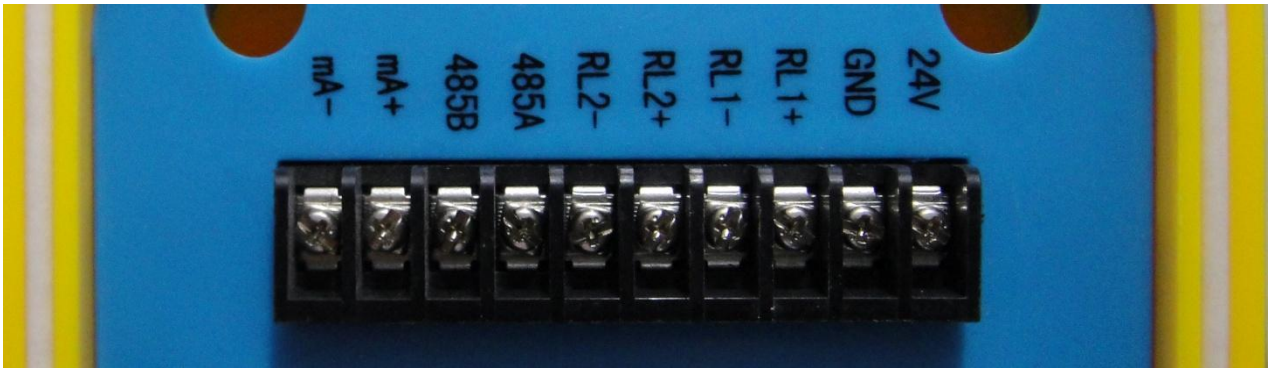

UFL8000 Terminal Box

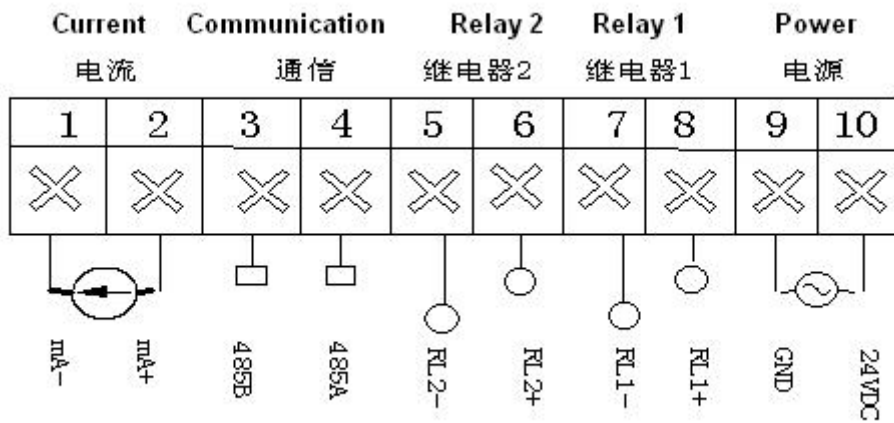

24 V DC Supply Wires Connection

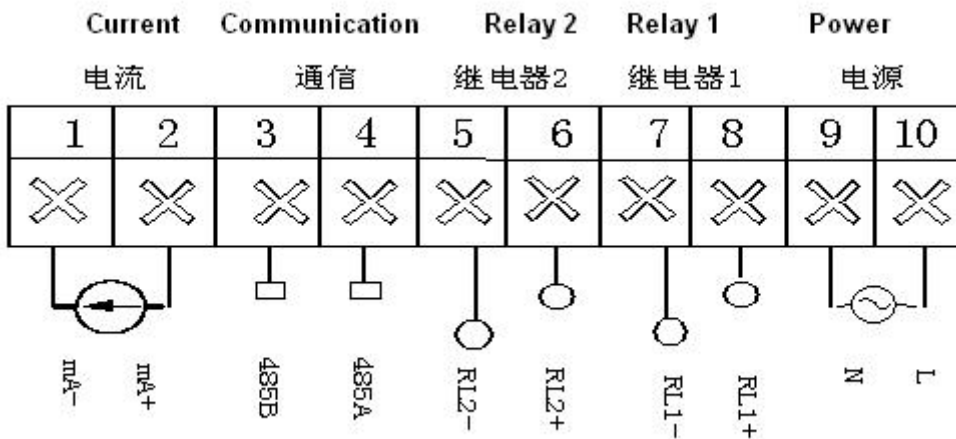

220 V AC Supply Wires Connection

1. 24 V DC Terminal Wires Connection:

Current: current+ connect with mA+; current - connect with mA-

Relay: RLn+ and RLn- are open, n = 1, 2

Power supply: 24V+ connect with 24VDC, GND connect with GND.

2. 220 V AC Terminal Wires Connection:

Current: current+ connect with mA+; current - connect with mA-

Relay: RLn+ and RLn- are open, n = 1, 2

Power supply: 220 V AC connects with L and N.

V. Setting

11

1、interface profile of operation mode

This series of ultrasonic open channel flow meter has two kinds of working mode: operation and setting. After device is electricity and completed the initial process, flow meter would enter operation mode automatically, and begin to measurement, record date.



2、menu query table see appendix table

3、Menu interface and instructions

(1) menu interface and operating explanation:

- ① Press SET key in operation mode to enter level 1 menu interface:
- ② item description of level 1 menu

◆ “0 End Setting”

When this item is chosen, press SET key back to the interface of operation mode.

◆ “1 Parameter Lock”

Menu locked, if you don't want others to change the parameters at will what you had set, lock the menu, after that, one should input the password first to unlock the menu and do some operation. The meter's initial password is 25, user can modify the initial password with any one for yourself (special remind: please keep your password in

mind, if you forget it, you should contact with manufacturer.)

Unlock: unlock, all menu can be modify at will.

Global lock: after global lock, one must input right password first then modify.

★ **When parameters were locked, press SET key to enter the unlock interface of parameter lock:**

◆ **“2 Range Setting”**

Reference point: Set reference point for open channel flow meter, it makes sense when the measurement is level measurement; **Factory setting defaults as maximum range.**

Low range: Set the measurement value of corresponding output when the level meter is 4mA; and it regards as the low limit value of flow, when level less than the set value, flow is 0. Factory setting defaults as 0.

High range: set the measurement value of corresponding output when the level meter is 20mA; and it regards as the high limit value of flow, when level greater than the set value, flow value hold set value. For example, if the set value is 0.5m, it means when level higher than 0.5m, hold 0.5m as the flow value. Factory setting defaults as maximum range.

Display unit: there are m, cm, mm, totally three kinds optional, m: shown as m, cm: shown as cm, mm: shown as mm, Factory setting defaults as m.

◆ **“3 Measurement Mode”**

Mode selection: Distance and level optional.

Distance measurement: shown value is the distance from transducer to been measured surface;

Level measurement: shown value is the distance from reference point to surface. Factory setting defaults as level measurement.

Response speed: Low, Middle, Fast optional.

Low: low response speed, high precision, no easy to be interference;

Middle: between low and fast;

Fast: high response speed, low precision, easy to be interference. Factory setting defaults as middle.

Safe level: Hold, minimum, maximum, set value four kinds optional.

Hold: if system lose wave, shown value is the last one that has measured, current is the corresponding value;

Minimum: if system lose wave, shown value is 4mA, current is 4mA;

Maximum: if system lose wave, shown value is 20mA, current is 20mA;

Set value: if system lose wave, shown vale is last measured one, current output is the set value. Factory setting defaults as hold.

Set current: set output current when system lose wave, greater than 3.6mA, less than 22mA, is invalid when the selection is hold/maximum/minimum. Factory setting defaults as 3.6mA.

◆ **“4 Transducer Setting” (please don’t modify this item)**

Selecting transducer and set relative parameters.

Transducer selection: there are 1~9 totally 9 kinds of choices. Choosing according to the label on transducer, Factory setting defaults as 5.

Blind area setting: Set the proximal blind area of transducer, Factory setting defaults as 0.30.

◆ **“5 Algorithm Selection” (please don’t modify this item)**

algorithm selection: There are special environment1, special environment2, special environment3, special environment4, special environment5, special environment6, special environment7, totally 7 items optional. Factory setting defaults as special environment7.

◆ **“6 Alarm Setting”**

Set alarm relay.

Alarm1 mode: close, low level alarm, high level alarm optional. Close: relay1 doesn’t work; low level alarm: relay1 low level alarm; high level alarm: relay1 high level alarm. Factory setting defaults as close.

Alarm1 value: the unit regards as m, Factory setting defaults as 0.

Alarm1 return difference: the unit regards as m, after trigger the alarm, remove alarm needs to measure alarm value+/-alarm return difference. Factory setting defaults as 0.

Alarm2 mode: close, low level alarm, high level alarm optional. Close: relay2 doesn’t work; low level alarm: relay2 low level alarm; high level alarm: relay2 high level alarm. Factory setting defaults as close.

Alarm2 value: unit regards as m, Factory setting defaults as 0.

Alarm2 return difference: unit regards as m, after trigger the alarm, remove alarm

needs to measure alarm value+/-alarm return difference.
Factory setting defaults as 0.

Alarm3 mode: use for the alarm of moment flow's upper and lower limit. Close, low level alarm, high level alarm optional. Close: relay3 doesn't work; low level alarm: relay3 low level alarm; high level alarm: relay3 high level alarm.
Factory setting defaults as close.

Alarm3 value: unit regards as t/h, Factory setting defaults as.

Alarm3 return difference: unit regards as t/h, after trigger alarm, remove the alarm needs to measure alarm value+/-alarm return difference.
Factory setting defaults as 0.

Alarm4 mode: used for the scale output of accumulative flow, it means every predetermined accumulative flow, close once, close time is 5s. Close, low level alarm, high level alarm optional. Close: relay4 doesn't work; low level alarm: relay4 low level alarm (set aside temporarily inactive); high level alarm: relay4 high level alarm. Factory setting defaults as close.

Alarm4 value: a preset cumulative flow. Unit regards as t, Factory setting defaults as 0.

◆ “7 Parameter Correction” (please don't modify this item)

For range correction, velocity correction, output current correction, reference level correction operation.

Range correction: Input real value, system corrects the range automatically.
Factory setting defaults as measured value.

Velocity correction: input real value, system proceeds to velocity correction automatically, used in the gas composition is not air.

4mA correction: Modify the value, until the real output current is 4mA. Factory setting defaults as 3100.

20mA correction: Modify the value, until the real output current is 20mA. Factory setting defaults as 7200.

Reference level: input the voltage value of corresponding measured point.
Factory setting defaults as 5.00.

◆ “8 Communication Setting”

Communication address: choose the address of the communication. Default value is 1.

Baud rate: Choose the frequency of the communication, 2400, 4800, 9600, 19200 optional, default value is 9600.

◆ “9 Set Constant”

Set every constant of flow meter.

Repair work coefficient: Set C value according to weir (**only parshall flume needs to be set**). Factory setting defaults as 0.01.

Index: set n value according to weir (**only parshall flume needs to be set**). Factory setting defaults as 0.01.

20mA flow value: Set 20mA flow value, it is the responding moment flow value when output is 20mA. Factory setting defaults as maximum flow speed.

4mA flow value: Set 4mA flow value, it is the responding moment flow value when output is 4mA. Factory setting defaults as 0.

Accumulate water: used for copy accumulate water when we changing meter. Factory setting defaults as 0.

Water clear: It reset the accumulate water to zero.

Timing sampling: Reserved item.

Flow unit: change the flow display unit, “t/h” is ton (cubic meters) /hour, “l/s” is liter/second, “t/s” is ton (cubic meters) /second. Factory setting defaults as “t/h”.

Interface switch: Switching between flow display interface and level display interface.

Output current: 4~20mA resistance loading capacity is 500 Ω. Used in flow meter, when 4~20mA, the output is according to flow; Used in level meter, the output is according to level. Factory setting defaults as level output.

Serial communication: The output of serial communication can be level value, and also can be moment flow speed, accumulate flow, factory setting defaults as flow output.

◆ “10 Weir Type”

Right triangle weir: close: means not to select the right triangle weir; open: means the selection is right triangle weir, under this case we don't need to input repair work coefficient c and index n, this machine uses querying method, gives flow velocity according to water level value directly. Factory setting defaults as “close”.

Rectangular weir: close: means not to select the rectangular weir;
0.25m (0.50m/0.75m/1.00m/other): means the selection is rectangular weir, these date said the larynx way's width of rectangular weir, for example 0.25m means a rectangular weir with a 0.25m larynx way's width, under this case we don't need to input repair work coefficient c

and index n , this machine uses querying method, gives flow velocity according to water level value directly, customer only need to choose different widths of larynx way. Default value is "close".

Parshall flume: close: means not to select the parshall flume; open: means the selection is parshall flume, default value is "open",

special note: at this time it requires user to input repair work coefficient c and index n , user can find out responding repair work coefficient c and index n according to different specifications of flume, then input them in menu item "9 set constant"

◆ "11 Reset Selection"

Factory reset: Yes: restore to the state of factory setting.

No: quit. Factory setting defaults as no.

System reset: Yes: restore to system setting.

No: Quit. Factory setting defaults as no.