

TECHNOLOGY

HOLYKELL®

HQF

FLOWMETER

• DATASHEET •

1. Pressure Measurement
2. Level Measurement
3. Temperature Measurement
- 4. Flow Measurement**
5. Display & Control Instruments
6. Wireless Monitoring System
7. Velocity Measurement

U shape Mass Flow Meter(HQF)

Product Introduction



The mass flow meter is based on the principle of Coriolis Force to realize the direct and precise measurement of the mass flow of fluid without conversion or correction of pressure, temperature, viscosity, density, etc. It is composed of two parts: a sensor unit and a transmitter unit. This instrument is designed and manufactured according to the national standard for intrinsic safety explosion-proof device, and the explosion-proof mark is EX d ib II C T6 Gb.

U-type mass flow meter can directly measure the quality of almost all the fluid, the application range is wide, including non-Newtonian fluids, various slurries, suspensions, high viscosity fluids, etc. And its installation requirement is not strict (low requirements for the front and rear straight pipe sections of the instrument), and it features reliable and stable operation, and low maintenance rate.

Product features

1. Refined digital signal processing enables accurate and stable measurement
2. Simple flow path means self-draining, food capable and simple to clean
3. Choice of tube materials: Stainless Steel 316L, Hastelloy C, etc

Specification

Parameter	Specification
Diameter	DN3mm-250mm
Medium temperature	-50°C~+150°C (-200°C~+350°C customizable)
Environmental Temperature	Sensor: -41°C~+150°C Transmitter: -41°C~+80°C
Accuracy of flow rate measurement	±0.5%, ±0.2%, ±0.1%±[(stability at zero point)/flow rate×100]% flow
Accuracy of density measurement	±0.002g/cm ² , ±0.001g/cm ²
Repeatability	±0.10%, ±0.05% flow±[½(zero point stability/flow value)×flow
Output signal	4~20mA load resistance <500Ω(Instantaneous flow or density optional, 0~10kHz Instantaneous flow pulse signal); 485 (MODBUS-RTU) Hart
Electrical Port	1/2" NPT
Explosion-proof grade	EX d ib II C T6 Gb
Protection grade	IP67
Work Temperature	-25~75°C
Storage Temperature	-40~85°C
Power supply	24V DC(220V AC or 24V DC and AC customizable)

General flow meter selection instructions

Instrument diameter (DN)	Measuring range(Kg/h)	Work pressure(MPa)	Connection Type(mm)
3	0~40	0~4	Φ6 connector
6	0~100	0~4	Φ8 connector
8	0~200	0~4	Φ8 connector
10	0~500	0~1.6	Flange DN10
15	0~1,000	0~1.6	Flange DN15
20	0~3,000	0~1.6	Flange DN20
25	0~10,000	0~1.6	Loose flange DN25
40	0~20,000	0~1.6	Flange DN40
50	0~30,000	0~1.6	Loose flange DN50
65	0~50,000	0~1.6	Flange DN65
80	0~100,000	0~1.6	Loose flange DN80
100	0~150,000	0~1.6	Flange DN100
125	0~200,000	0~1.6	Flange DN125
150	0~500,000	0~1.6	Flange DN150
200	0~800,000	0~1.6	Flange DN200

Description: 1. the standard of the flanges above is HG/T 20592-2009.
2. Other connections can be customized.

High pressure flow meter selection instructions

Instrument diameter (DN)	Measuring range(Kg/h)	Work pressure(MPa)	Connection Type(mm)
3	0~40	0~25	Φ6 connector
6	0~100	0~25	Φ8 connector
8	0~200	0~25	Φ8 connector
10	0~500	0~25	Welded movable connector Φ20×4
15	0~1000	0~25	Welded movable connector Φ20×3
20	0~3000	0~25	Welded movable connector Φ20×2
25	0~10000	0~25	Welded movable connector Φ31×3
40	0~20000	0~25	Welded movable connector Φ42×5.5
50	0~30000	0~25	Welded movable connector Φ57×3.5

Description: 1. Higher pressure type can be customized(100MPa max) .

2. Other connections can be customized.

It is recommended that the commonly used is 1/3 higher the standard range, and the minimum flow is over 1/10 of the standard range. For special needs, please specify when ordering, we can make calibrations according to the user's special needs to ensure that the instrument meets the requirements within the user's use range. According to the actual material characteristics, select the material, pressure level and temperature level of the instrument sensor, and ensure that the explosion-proof level meets the customer's requirements.

Drawings

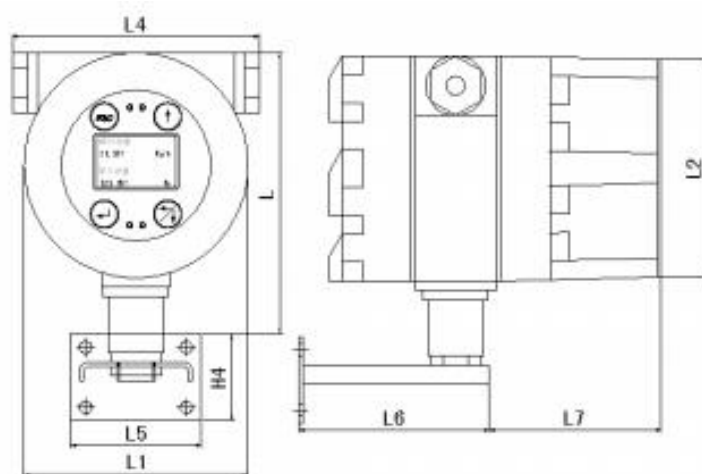

Unit, mm

Name	L	L1	L2	L4	L5	L6	L7	L8	L9	H4
Transmitter	156	125	118	130	54	102	180	45.5	85	32

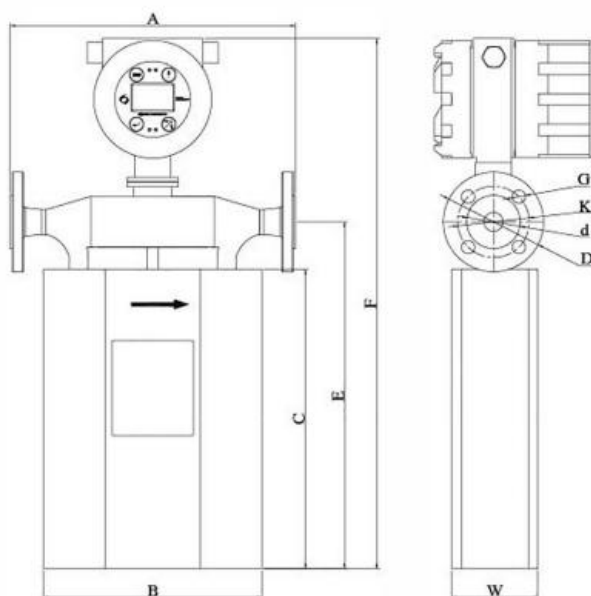

U Shape Dimensions

Model No.	DN	Pressure MPa	A	B	C	E	F	W	G	K	d	D
HQF -1-U10	10	4	280	210	235	285	495	80	14	60	40	90
HQF -1-U15	15	4	280	210	275	325	535	80	14	65	45	95
HQF -1-U20	20	4	300	230	325	375	585	90	14	75	58	105
HQF -1-U25	25	4	410	300	440	500	715	120	14	85	68	115
HQF -1-U40	40	4	500	360	480	585	805	130	18	110	88	150
HQF -1-U50	50	4	550	370	548	670	890	153	18	125	99	165
HQF -1-U65	65	4	560	440	600	715	955	200	18	145	122	185
HQF -1-U80	80	4	600	470	650	767	1005	220	18	160	138	200
HQF -1-U100	100	1.6	620	510	740	858	1110	260	18	180	158	220
HQF -1-U125	125	1.6	620	510	740	858	1110	260	18	210	188	250
HQF -1-U150	150	1.6	785	670	950	1130	1370	280	22	240	212	285
HQF -1-U200	200	1.6	800	670	950	1130	1370	280	22	240	212	285
HQF -1-U250	250	1.6	815	670	950	1130	1370	280	22	240	212	285

How to Order

Description:

- Default flange grade: 150LB for foreign countries, 4MPa for domestic; higher pressure can be customized, up to 100MPa;
- The default is integrated type, and the split can be customized (the cable length needs to be notified in advance);
- Default flange standard: Weld Neck Flanges-ANSI B16.5 for foreign countries, HG/T 20592--2009 in domestic; other connection methods can be customized.

Selection Notes:

- To measure liquids, it is necessary to combine the common flow rate and the maximum and minimum flow rate, and choose an instrument with a suitable range.
- The measurement gas, combine with the process pipe diameter, pressure, commonly used amount, maximum and minimum amount to calculate the flow rate selection.
- When measuring high-viscosity fluids or liquid-solid two-phase fluids, it is necessary to inform the viscosity, density, process pipe diameter, common volume, and maximum and minimum flow rates.
- When measuring corrosive medium, please inform the chemical name of the specific medium, and select the measuring tube of different materials (316L, HC276, HC22, C4 steel, 2205 steel, lined with PTFE) according to the corrosion manual.

Product Model HQF	
DN	Measuring Range
S3=DN3mm	0~40kg/h,0~4kg/h(For high viscosity fluids and gases, etc.)
S6=DN6mm	0~100kg/h,0~10kg/h(For high viscosity fluids and gases, etc.)
S8=DN8mm	0~200kg/h,0~20kg/h(For high viscosity fluids and gases, etc.)
U10=DN10mm	0~1000kg/h,0~100kg/h(For high viscosity fluids and gases, etc.)
U15=DN15mm	0~2000kg/h,0~200kg/h(For high viscosity fluids and gases, etc.)
U20=DN20mm	0~3000kg/h,0~300kg/h(For high viscosity fluids and gases, etc.)
U25=DN25mm	0~10t/h,0~1t/h(For high viscosity fluids and gases, etc.)
U40=DN40mm	0~20t/h,0~2t/h(For high viscosity fluids and gases, etc.)
U50=DN50mm	0~30t/h,0~3t/h(For high viscosity fluids and gases, etc.)
U65=DN65mm	0~50t/h,0~5t/h(For high viscosity fluids and gases, etc.)
U80=DN80mm	0~100t/h,0~10t/h(For high viscosity fluids and gases, etc.)
U100=DN100mm	0~150t/h,0~15t/h(For high viscosity fluids and gases, etc.)
U125=DN125mm	0~200t/h,0~20t/h(For high viscosity fluids and gases, etc.)
U150=DN150mm	0~500t/h,0~50t/h(For high viscosity fluids and gases, etc.)
U200=DN200mm	0~700t/h,0~70t/h(For high viscosity fluids and gases, etc.)
U250=DN250mm	0~800t/h,0~80t/h(For high viscosity fluids and gases, etc.)

Accuracy

A=±0.5% **N=±0.2%** **M=±0.15%** **H=±0.10%**

Sensor temperature level(it is a split type when <50°C or >250°C)

A=-50~150°C B=-50~250°C C=-50~350°C D=-200~150°C

Pressure resistance class(100MPa max)

16=1.6MPa 40=4.0MPa XX=Others on request

Measuring tube material

A=316L for medium contact part C=HC alloy for medium contact part

D=The inner wall surface is sprayed with tetrafluoroethylene E=Others on request

Process connection

F=Standard flange W=Sanitary type L=welding screw T=Others on request

Body material

A=304 Stainless steel B=316 stainless steel

Transmitter installation

A=Integrated installation B=Split installation, with bracket

Transmitter ambient temperature

A=-20~50°C B=-41~80°C

Transmitter output

A=4-20mA(Instantaneous flow or density optional:0~10KHz(Instantaneous flow pulse signal);RS485 Modbus RTU

B=4-20mA(Instantaneous flow or density optional:0~10KHz(Instantaneous flow pulse signal);RS485 Modbus RTU;HART

Transmitter housing

B=Die-cast aluminum alloy housing, electrical interface:M20×1.5

C=Die-cast aluminum alloy housing, electrical interface:1.2" NPT

Explosion proof level

A=Exd ib II CT6 Gb

IP Rating

A=IP67

For example: HQFU10A16AFAAAABAA