

TECHNOLOGY

HOLYKELL®

**SP SERIES MAGNETOSTRICTIVE
PROBE**

User Manual

HOLYKELL TECHNOLOGY CO.LTD

Introduction

Welcome to choose Automatic Tank Gauging (ATGs) System of Holykell. You are strongly recommended to read this manual before installation.

The installation and maintenance for the products must be done by the qualified technicians.

Safety instruction

The ATGs system is installed in gas station and oil depot, please read safety instructions for explosion protection.

Power must not be switched on before installation & maintenance.

The cable from probe must be connected to Holykell GSB03 safety barrier.

The products are prohibited to be installed in explosion proof area over its own Ex level.

The console and printer must be installed in safe area, such as office.



Safety warning

The tank must have earth busbar, the earth must be safe and reliable. ATGs system must share the same earthing with tank.

Unpack and check

Please check all the materials according to the list. If anything missed, please contact the local representative or distributor directly. You can also find the contact information of Holykell in this manual.

Quality Track Card

After installation, please post the Quality Track Card to Service Department of Holykell for fast and right service. Thank you very much!

Content

Introduction	1
1. Brief introduction of SP series magnetostrictive probe	3
2. Technical parameters of probe	4
2.1 Electrical parameters of probe.....	4
2.2 Outline Dimension	5
3. Installation and construction in service station	6
3.1 Attention and requirement during installation	6
3.2 Installation of riser pipe and its flange.....	7
3.3 Construction requirements of manhole.....	8
3.4 Layout of protection steel pipe and communication cable.....	9
3.5 Installation of probe.....	10
3.6 Installation of explosion proof flexible pipe and explosion	11
3.7 ATGs system electrical connection figure.....	13
4. Selection of probe specification	14

1. Brief introduction of SP series magnetostrictive probe

Holykell SP series magnetostrictive probe take advantages of Wiedeman effect, Viuary effect and ultrasonic effect of intelligence material, convert displacement information to time value which most easily to be measured with high-precision, so achieve high accuracy measuring for liquid level. Because of few mechanical parts, magnetostrictive probe have distinct features as high reliability 、 easy-to-install and wide application, etc.

Magnetostrictive probe is mainly composed of electric house 、 temperature sensors 、 protection steel pipe 、 magnetostrictive waveguide wire and floaters with magnet inside. Install electric house inside the riser pipe of oil tank, insert protection steel pipe into liquid in underground tank, floaters floats on the liquid surface, and slides up and down on pipe according to the changes of liquid level. Processing measured data of product level 、 water level and average temperature of five-points by filtering algorithm, then transmit these data to smart console by digital communication port.

Control board of probe is composed of CPU 、 instrument amplifier circuit and communication circuit. CPU adopts high-frequency processor, to ensure the instantaneity and reliability of data sampling. High-accuracy instrument amplifier circuit makes sure the authenticity of sampled data waveform. And digital communication make sure the reliability and anti-jamming when data transmit far away.

2. Technical parameters of probe

2.1 Electrical parameters of probe

Power supply	DC12V, 50mA
Range/Probe Length:	0-1m...5m customized
Precision	±0.5mm(0...3.17m) ; ±1.0mm(3.17...4m); ±1.5mm(4.1...4.5m); ±2.0mm(4.6...5.0m);
Repeatability	±0.2mm
Resolution of product level	0.01mm
Resolution of temperature	0.0625°C
Resolution of water level	0.01mm
Temperature range	-40°C ~ 60°C;
Points of temperature measured	5
Maximum communication	500m
Communication	RS-485
Intrinsic safety parameter	Power port: $U_i = 15V, I_i = 400mA, P_i = 1.2W, C_i = 4.85\mu F, L_i = 0;$
	Signal port: $U_i = 7.14V, I_i = 147mA, P_i = 0.26W, C_i = 0, L_i = 0;$
Mark of explosion proof	Exia II AT4
Associated apparatus	Holykell GSB03 safety barrier
Definition of power cable	BLUE – POWER BROWN – RS-485A WHITE – RS-485B BLACK – GND
Medium applicable	Gasoline, kerosene, diesel, light oil, heavy oil ,alcohol mixture,
Communication address	6 digits, please see “Manufacturing Code ” on nameplate of probe

2.2 Outline Dimension

SP100 (discontinued)

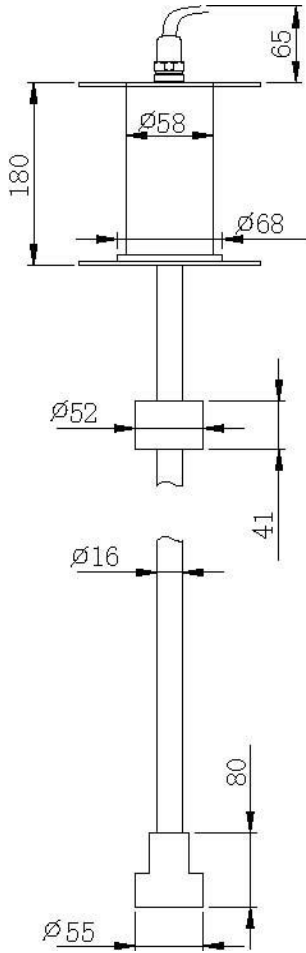

Oil floater

SP300

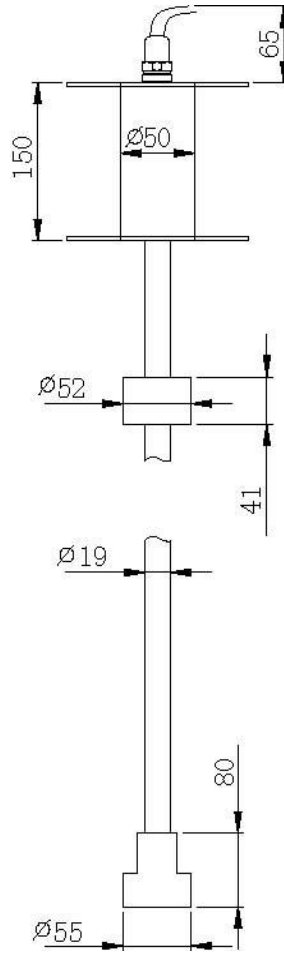

Water floater

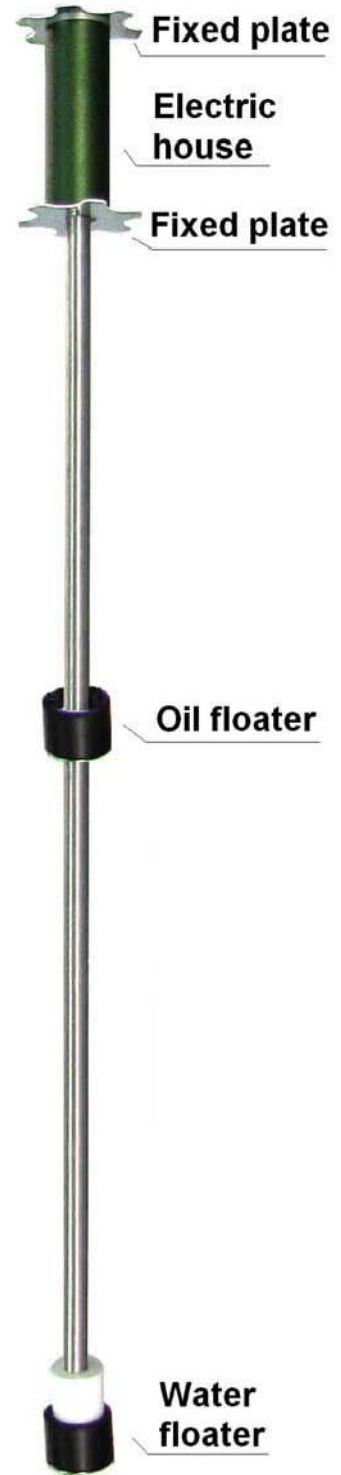

3. Installation and construction in service station

The installation quality of ATGs system and its accessories have a close bearing on safety, service quality, measuring accuracy and lifetime.

In order to operate safely, please conform to this manual. If out of accord with local regulation, please install and operate according to local regulation.

3.1 Attention and requirement during installation

Please keep the distance between probe, delivery pipe and suction pipe more than 1 meter. Otherwise, the oil flow will influence on the probe performance, even bend and damage the probe.

During the installation, it is important to adjust outlet direction of delivery pipe to opposite to the probe.

Riser pipe must be welded vertical (vertical for horizontal not for manhole cover), insert into manhole cover but not more than 100mm. Internal wall of riser pipe must be smooth and no welding slag. Correct installation please sees Fig 1 as below.

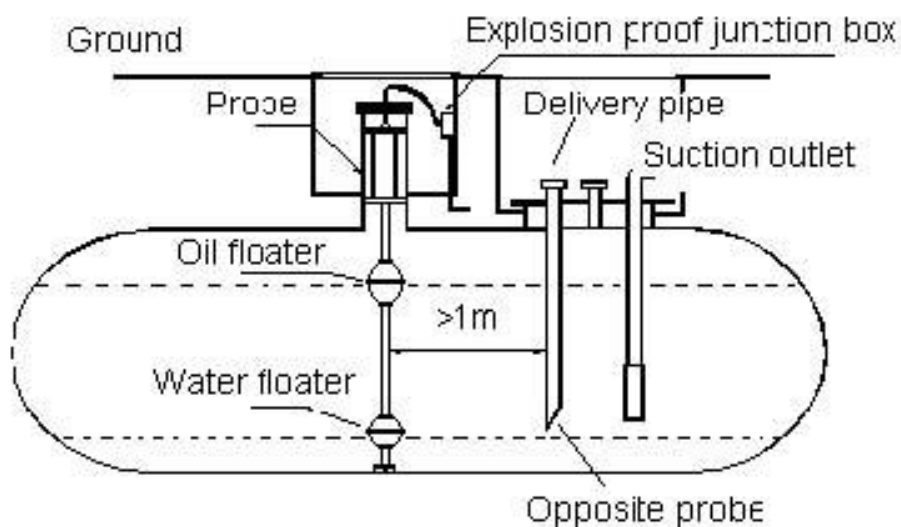

Fig. 1

3.2 Installation of riser pipe and its flange

For Holykell probe, internal diameter of riser pipe is 100mm(4"). Length of the pipe should more or equal to 350mm, design please refers to following Fig 2.

Open a cable hole on the center of blind flange, fix G1/2 screw for cable pass and seal. Flange design please refers to following Fig 3.

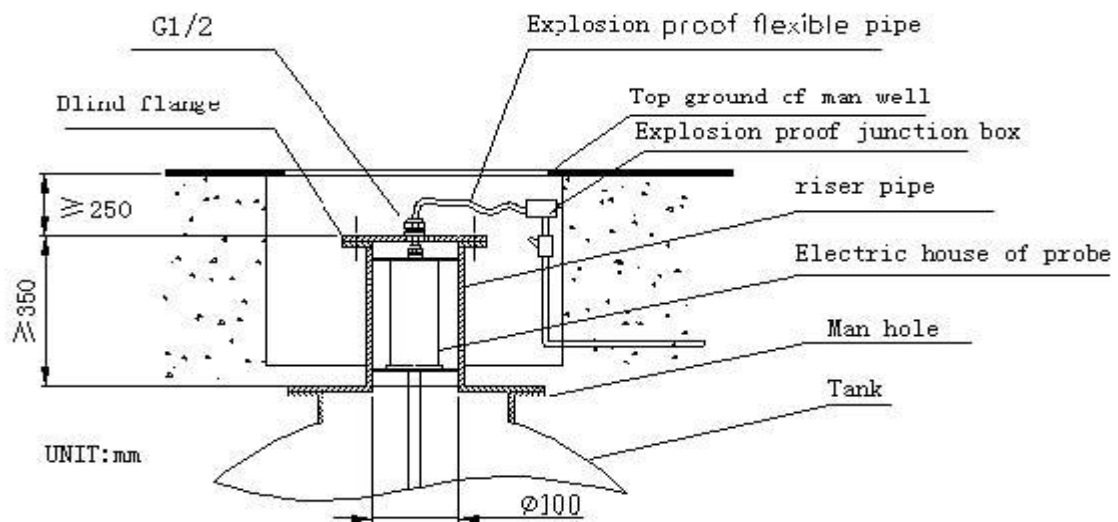

Fig. 2

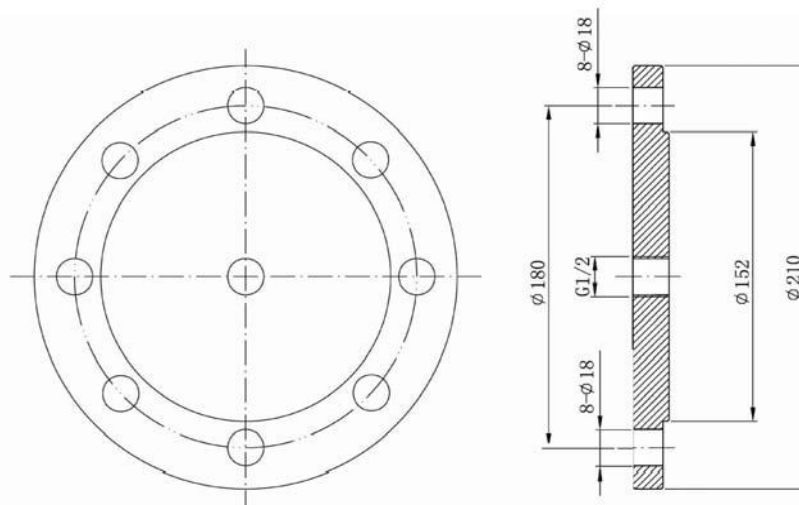

Fig. 3

3.3 Construction requirements of manhole

Man-well opening should be larger than 800x800mm, for convenient to construct.

Man-well opening must have a wall higher than 300mm, to avoid outside water penetrating into . Man-well also has cover above.

The distance between man well opening and blind flange of riser pipe should be more than 250mm, for the installation of explosion proof flexible pipe.

There must be asbestos pad between riser pipe flange and blind flange, and jointing with sheet copper.

Earth sheet iron must be reliable connected to the earth system of underground tanks, earth resistance should less than 1 Ω .

Earth wire should larger than 6 m m², and connect to earth sheet iron reliably.

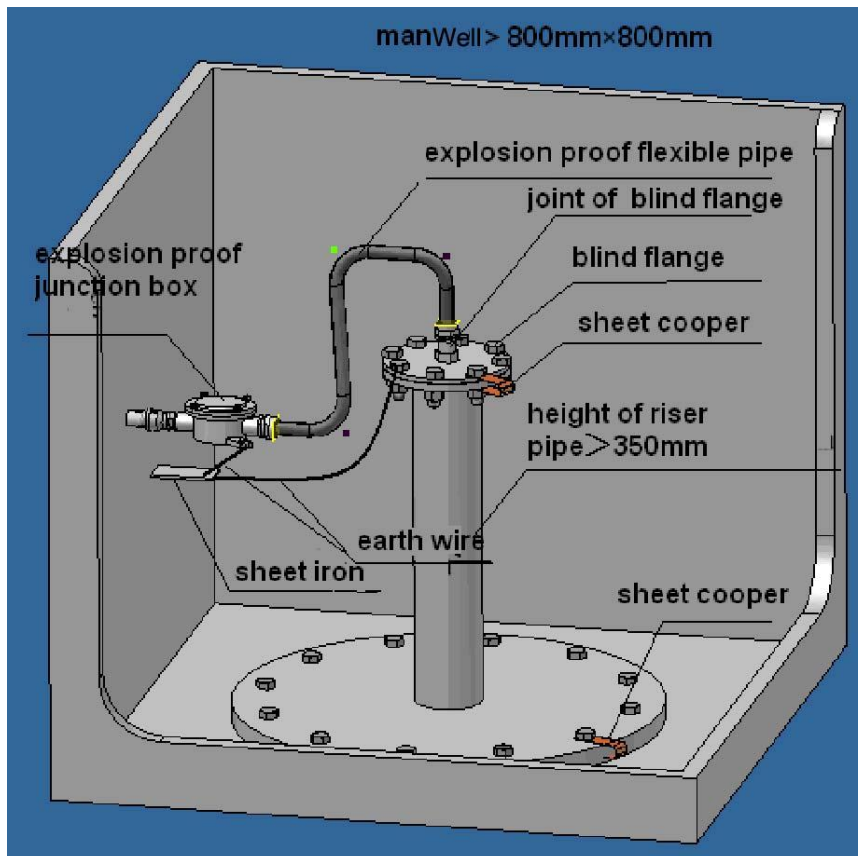

Fig 4.

3.4 Layout of protection steel pipe and communication cable

Please see Fig. 5 as below.

- All communication cables must go through protection steel pipe.
- When lying, protection steel pipe must be put under ground at least 300mm depth. Spacing distance between pipes must be at least 200mm.
- Corner of protection steel pipe must be one-round turn for cable to through easily.
- Each cable of probe must be put in separate pipe.
- The cable from smart console to probe must be complete one, shouldn't have any joint.
- For safety, we recommend use RVVP4×0.5 (or larger) shield cable and must accord with the requirement of capacitance per foot not more than 100pF, length of cable less than 300m. Shielding layer of cable from probe must be coupled with PE port of console, the shielding layer of cable in explosion proof junction box should be wrap up well by black tape,
- Protection steel pipe should be coupled with the earth system of gas station.
- The end of pipe which inside control room must be injected into silicon rubber, to ensure reliable sealing and avoid vapor going into room.

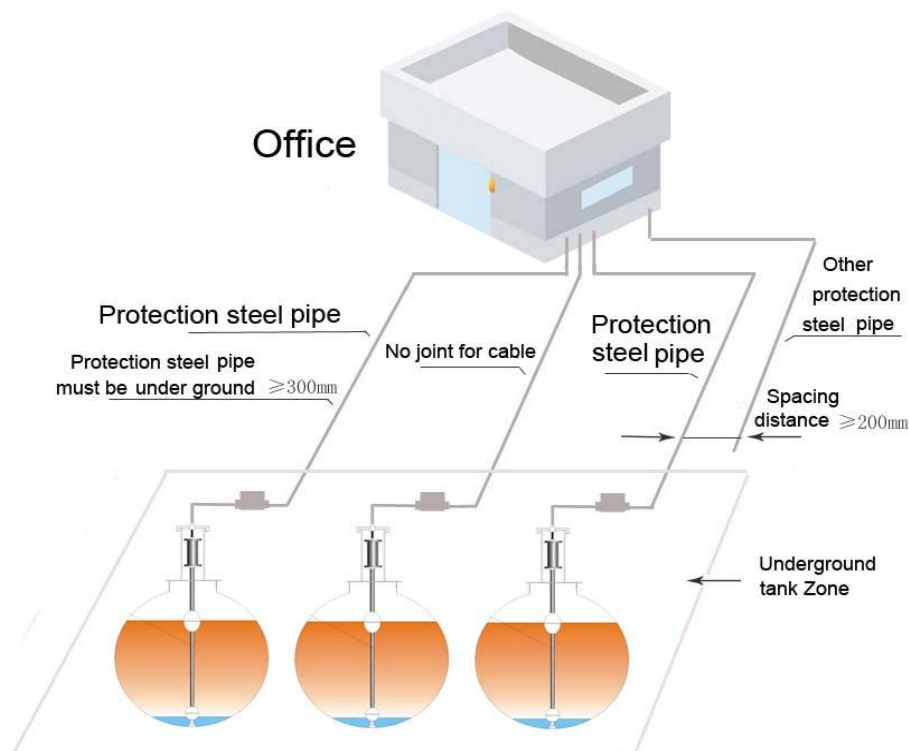

Fig. 5



Safety warning

To ensure normal work of gas station safety system, the anti-lightning system of gas station should be able to protect the whole ATGs system, and reserve earth port for ATGs system.

3.5 Installation of probe

Notice

1. For probe is high-precision product, please take carefully when moving!
2. Please make sure the vertical of probe, otherwise will affect measure precision.
3. Don't draw-off communication cable of probe when installation.
 - Take probe out of package box.
 - Record "Manufacturing Code" on nameplate of probe, in reserve for communication.
 - Remove foam package of probe
 - Install fixed plate at top and bottom of electric house.
 - Insert communication cable to the socket at top of electric house tightly.
 - Carefully put oil floater and water floater at the bottom of probe.
 - Insert probe into oil tank carefully by two hands, then hold fixed plate and adjust probe to be vertical, installation position please see Fig 6.

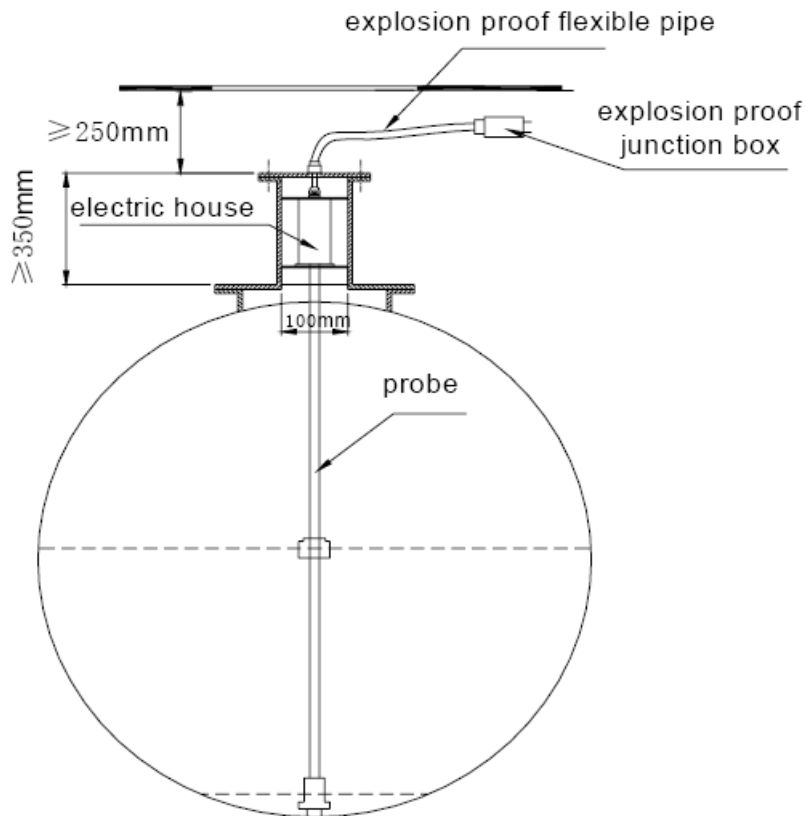

Fig 6



Safety warning

When installation, must use anti-static tools, like copper spanner, screwdriver

3.6 Installation of explosion proof flexible pipe and explosion

proof junction box. Details please see Fig. 7 following



Safety warning

1. Every accessory must be installed in order, don't confused.
2. Explosion-proof block must be full filled with explosion proof rubber, to prevent oil gas enter into control house through protection steel pipe.
3. Cables must be tightly compressed by sealing element, to avoid oil gas penetrates into.
4. All accessories must be tightened.

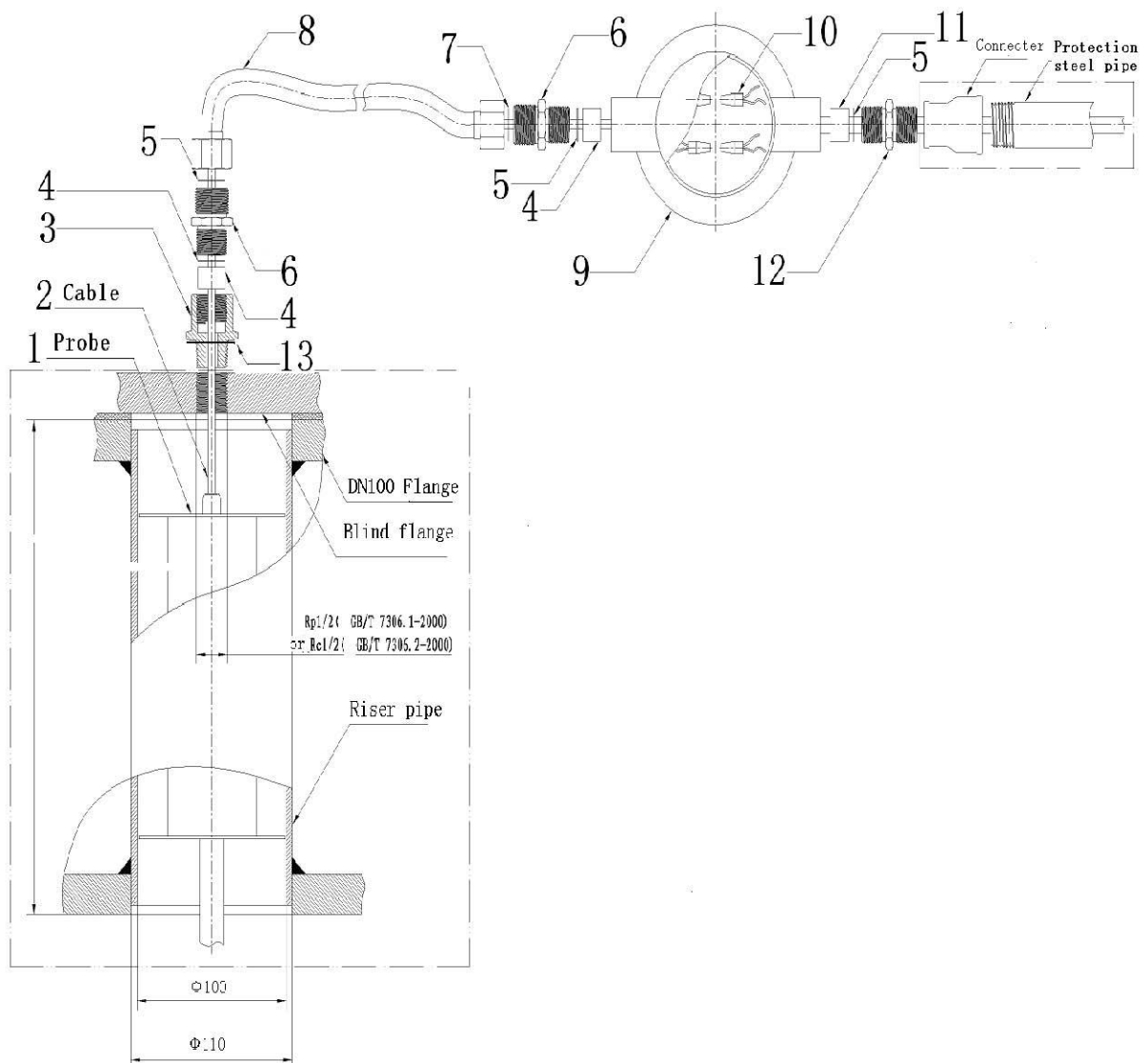

Fig. 7

Table.1

Item	Name	Specification	Qty.	Remark
3	Joint of blind flange	G1/2-G1/2	1	For cable sealment and connection with oil tank
4	Sealing rubber plug	Φ18×Φ5×18	2	For probe communication cable
5	Metal gasket	Φ18×Φ10×1	3	For all sealing rubber plug
6	Joint of explosion proof flexible pipe	G1/2-M30×1.5	2	Standard configuration for explosion proof flexible pipe
7	Seal gasket		2	Standard configuration for explosion proof flexible pipe
8	Explosion proof flexible pipe	G1/2 ×0.7~1.5m	1	
9	Explosion proof junction box		1	
10	Wire nut		5	4 pcs for each probe, one more for spare
11	Sealing rubber plug	Φ18×Φ10×18	1	For shielding cable RVVP4×0.5
12	Joint of protection steel pipe	G1/2-G1/2	1	Connect between protection steel pipe and explosion proof junction box
13	Sealing ring	Φ29×Φ19×2.2	1	For joint of blind flange

3.7 ATGs system electrical connection figure

The cable from probe must be correctly coupled into relevant safety barrier inside console. The shielding of cable must be coupled into PE of safety barrier. The safety barrier also must be coupled into earth reliably. As Fig 8 shown.

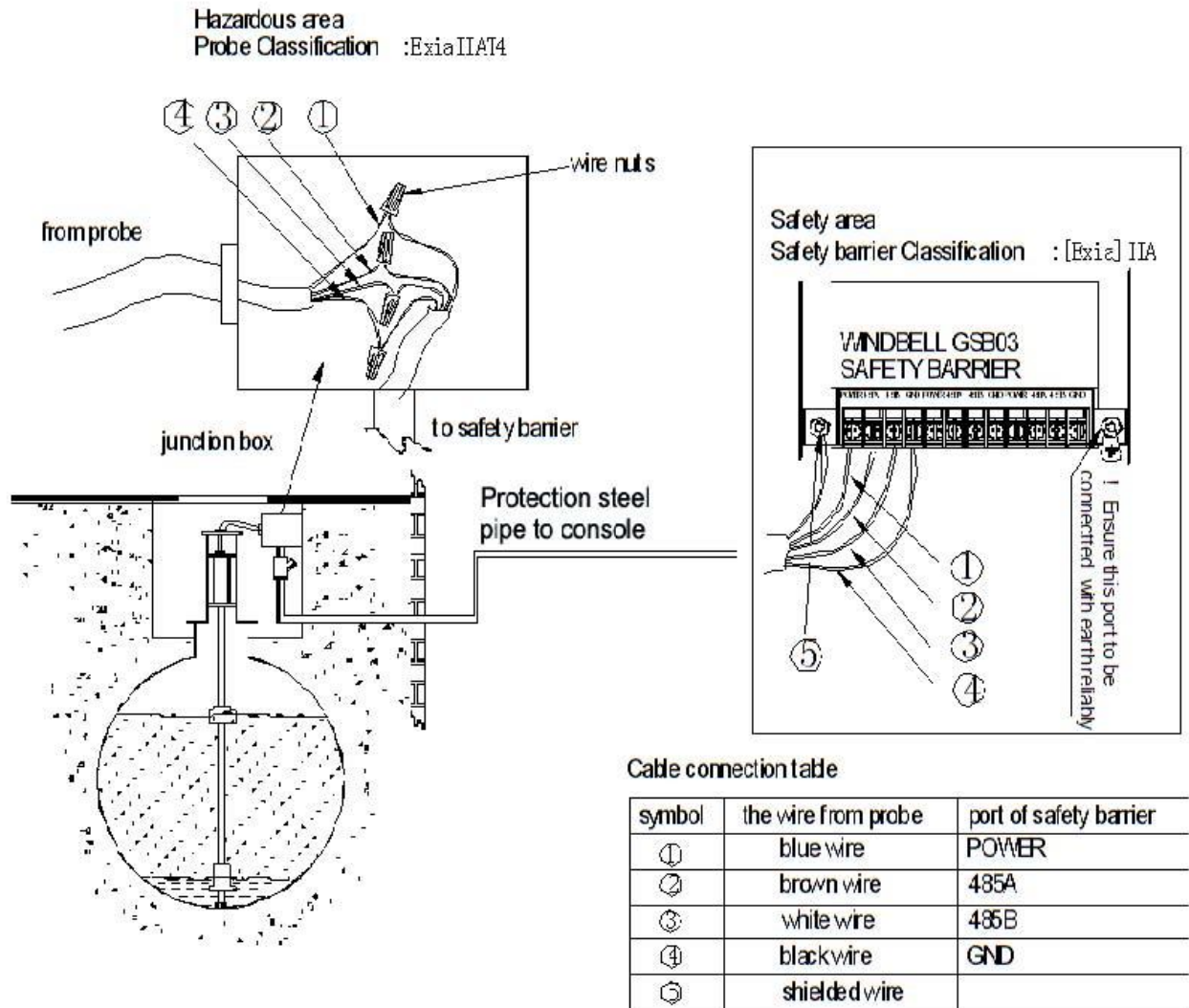

Fig 8

Safety warning

- Earth terminal of safety barrier should reliable connects to ground by more than 6 mm² multi-core copper cable.
- Forbid turning on power for the system before correct couple with cables.
- ATGs system must share the same earthing with tank

4. Selection of probe specification

For SP100 and SP300 probe, different lengths have different specification. For example, SP300-2870, that's means model is SP300, length of probe rod (below electric house) is 2870mm.

The selection of probe length as below,
 Probe length (1) = Oil tank diameter (2) + height of manhole (3) + 80mm

In addition, please indicate oil product when order to us, we will provide with different floaters.

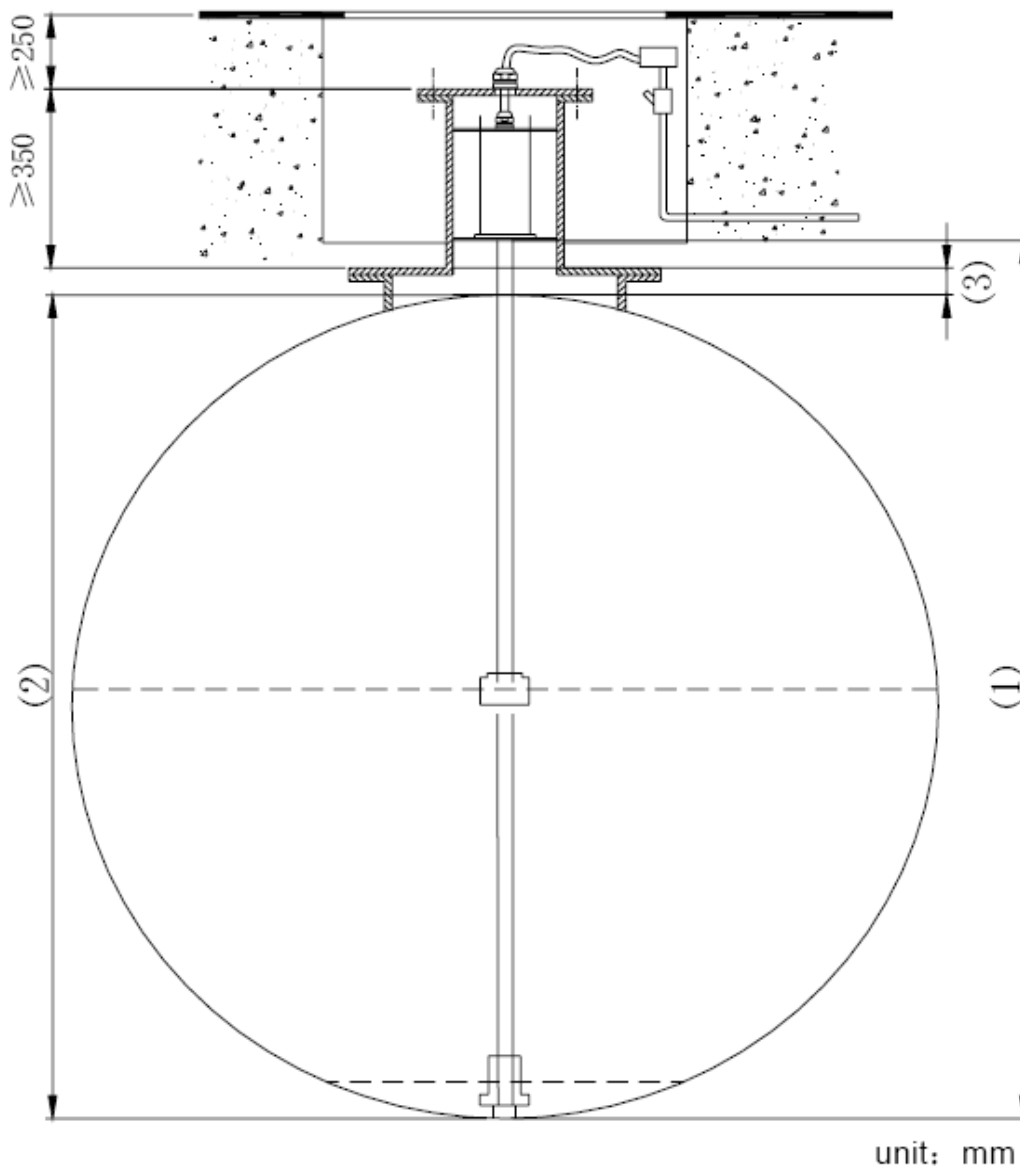

Fig. 9

HOLYKELL

is dedicated in providing solution to
environment protection & safety
for petroleum industry

HOLYKELL TECHNOLOGY CO.LTD.

V2.0