

TECHNOLOGY

**HOLYKELL®**

**HGUF**  
**FLOWMETER**  
• DATASHEET •

1. Pressure Measurement 2. Level Measurement 3. Temperature Measurement  
**4. Flow Measurement** 5. Display & Control Instruments

# HGUF Gas Ultrasonic Flow Meter

## Product Introduction



HGUF Gas ultrasonic flow meter is produced by advanced German technology. All its key components are imported from original equipment, featuring high reliability and long service life. It is a new type of precision measuring instrument with high precision and high reliability. It can be widely applied to gas flow measurement in urban gas, petroleum, chemical industry, electric power, metallurgy and other industries.

It adopts mono and multi-channel designs respectively, and the length of the pipe section of the mono ultrasonic flow meter can directly replace the current mainstream turbine flow meter in the market and has higher cost performance. Multi-channel ultrasonic flow meter adopts redundant design. Each channel can be measured separately. If one channel fails, other channels will continue to be measured reliably to improve the reliability of the system.

## Product Features

- Made with German Advanced Technology
- Multiple options for mono and multi-channel measurements
- Eddy Current and Asymmetric Flow Detection
- Laminated shielding of electric and magnetic fields, high noise immunity
- Zero drift automatic correction, accuracy is not affected by the environment

- Measurement accuracy grade: 1.0
- Ultra-wide range ratio 1:40
- Ultra-low "zero" starting flow rate
- The metering range can cover Roots meter and turbine meter.
- Double backup lithium battery power supply
- High precision temperature and pressure compensation, volume correction
- Intelligent switch of various gas working conditions and standard temp. and pressure
- Mass storage, saving data for one year
- Intelligent fault detection, fault alarm
- Maintenance-free, cleaning-free, long service life
- The meter can be rotated 180 degrees to facilitate reading.

## Working Principle

### 1. Basic Working Principle of Ultrasonic Flow Meter

Ultrasonic flow meter is based on the principle of measuring the relationship between the time of sound wave propagation in flowing medium and the flow rate. It is generally believed that the actual propagation speed of acoustic wave in fluid is determined by the propagation speed ( $C_f$ ) of acoustic wave in the static state of the medium and the axial average velocity ( $V_m$ ) of fluid

Component composition in the direction of sound wave propagation. As shown in fig. 1, the relationship between downstream and upstream propagation time and each quantity is:

$$t_{down} = t_{AB} = \frac{L}{(C_f + V_m \cos \emptyset)} \quad t_{up} = t_{BA} = \frac{L}{(C_f - V_m \cos \emptyset)} \quad (1)$$

In the formula:

- $t_{up}$  ———the time when the sound wave propagates countercurrently in the fluid;
- $t_{down}$  ———the time when the sound wave propagates in the fluid along the current;
- $C_f$  ———the speed at which sound waves travel in fluids;
- $V_m$  ———axial average velocity of fluid;
- $\emptyset$  ———channel angle;

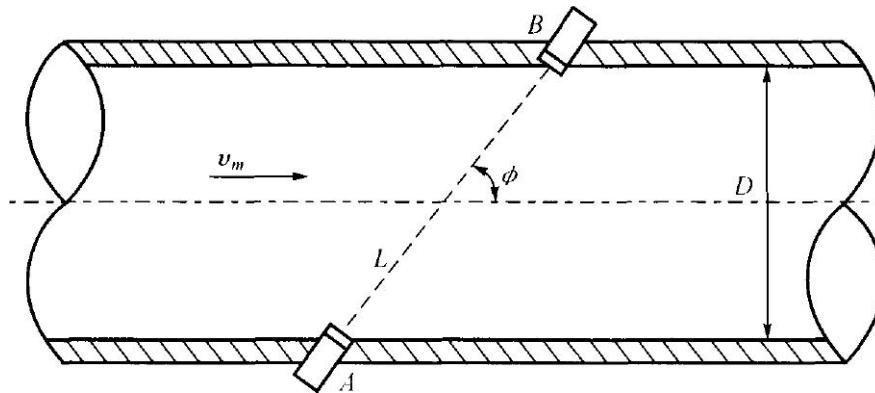

Fig. 1 general schematic diagram

Using equation (1), the expression of fluid flow rate can be obtained:

$$V_m = \frac{L}{2 \cos \phi} \left( \frac{1}{t_{down}} - \frac{1}{t_{up}} \right) \quad (2)$$

The measured fluid flow rates  $V_i$  ( $i=1,2,\dots,k$ ) of a plurality of channels; The estimated value of the average flow rate  $\bar{V}$  of the pipeline can be obtained by combining the mathematical functional relations, and the volume flow rate  $q_v$  can be obtained by multiplying the estimated value by the flow area  $A$ , as shown in Equation (3):

$$q_v = A \bar{V} \quad (3)$$

$$\bar{V} = f(V_1, \dots, V_k) \quad (4)$$

Type:  $k$  ——— Number of channels

## 2. Accurate Time of Flight Measurement Based on Echo Response

The key technology of ultrasonic flow meter is to accurately measure the flight time of acoustic wave in fluid, and the flight time consists of inherent delay  $\epsilon$  (uncertainty) of sensor and flight time  $t_0$  in fluid, as shown in fig. 2.

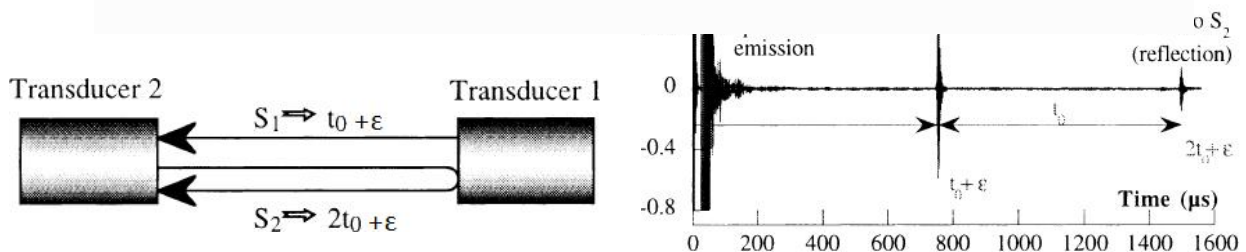

Fig. 2 schematic diagram based on echo response

$$\text{That is, } t_1 = t_0 + \varepsilon \quad t_2 = 2t_0 + \varepsilon \quad (5)$$

$$t_0 = t_2 - t_1 \quad (6)$$

Therefore, the uncertain inherent delay  $\varepsilon$  of the sensor and the processing circuit is eliminated, and the flight time  $t_0$  of the acoustic wave in the fluid is accurately measured.

### 3. Multiplex Multi-channel Ultrasonic Flow Meter

The ultrasonic flow meter designed by multiplexing multi-channel has the characteristics of high noise resistance, capability of detecting eddy current and asymmetric flow, elimination of uncertain inherent delay of sensors and processing circuits, accurate measurement, etc. At the same time, the multiplexed channel can be used as redundant backup. Even if the individual sensors are damaged, this ultrasonic flow meter can still work normally, greatly improving the reliability of detection.

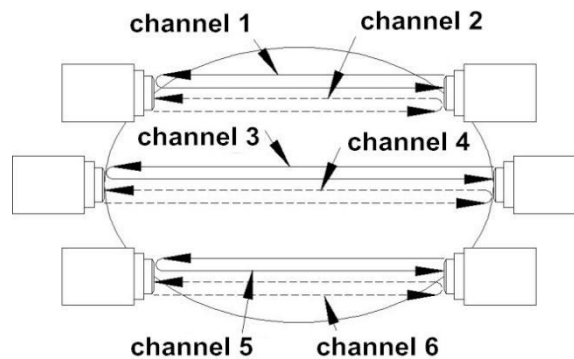

Fig. 3 schematic diagram of multiplex multi-channel

### 4. Working Principle of Volume Correction

Volume correction multi-channel signals sent by temperature, pressure and flow sensors are substituted into formula operation by microprocessor according to gaseous equation to realize real-time display and signal remote transmission.

$$\text{Gaseous equation: } V_0 = V * \frac{(P_a + P_g)T_0}{P_0T} * \frac{Z_n}{Z_g} = V * \frac{P}{P_0} * \frac{T_0}{T} * F_z^2 \quad (7)$$

- Where,  $V_0$  —— volume in standard state (m<sup>3</sup>)
- $V$  —— volume under working condition (m<sup>3</sup>)
- $P = P_a + P_g$  —— absolute pressure (kPa) at pressure detection point of flow meter
- $P_a$  —— local atmospheric pressure (kPa)

$P_g$  — gauge pressure (kPa) at pressure detection point of flow meter

$P_0$  — standard atmospheric pressure (101.325kPa)

$T_0$  — absolute temperature in standard state (293.15K)

$T$  — absolute temperature (293.15+t)K of measured medium

$t$  — temperature of medium to be measured (°C)

$$F_z = \sqrt{\frac{Z_n}{Z_g}} \quad \text{— Gas compressibility factor}$$

$Z_n$  — Gas Compression Coefficient in Standard State

$Z_g$  — Gas Compression Coefficient in Working State

## Technical Performance Specification

### 1. Measurement Accuracy Grade

The accuracy level of measurement within the range is 1.0

0.1 $Q_{max}$ ~ $Q_{max}$  maximum permissible error:  $\pm 1.0\%$ , repeatability:  $\pm 0.2\%$

### 2. Electrical Performance Indicators

#### 2.1 Working power supply

- Internal power supply: 3.6V lithium battery (model ER34615), which displays the battery capacity in real time.
- External power supply: 5~24VDC, ripple  $\leq 50\text{mV}$ , the system automatically switches external power supply, and the external power supply adopts DC-DC management mode. ( Safety barrier shall be installed when using intrinsic safety function)

#### 2.2 Overall power consumption

- Internal power supply: average power consumption  $\leq 1.5\text{mW}$ , two lithium batteries can be used continuously for more than 6 years.
- external power supply: average power consumption  $\leq 1\text{W}$

#### 2.3 Input Signal

- Flow signal: 200 KHz $\pm 10\%$ ,  $V_{pp} \geq 10\text{mV}$
- Temperature signal: analog signal output by temperature sensor
- Pressure signal: analog signal output by pressure sensor

#### 2.4 Output Signal

- Working condition pulse signal output (3-wire system) FOUT: pulse signal output high level  $\geq (V_{\text{external}} - 2\text{V})$ , low level  $\leq 0.5\text{V}$ , drive current  $\geq 20\text{mA}$ , transmission distance  $\leq 50\text{m}$ , powered by external power supply.

- IC card pulse signal output (two-wire system) IC\_out: CMOS level, output in pulse signal string mode, normally low level. The pulse output format can be selected, and the volume flow represented by one pulse is set by the output pulse equivalent, namely 0.1m<sup>3</sup>、1m<sup>3</sup>、10m<sup>3</sup>; The level width is set by the output pulse width, which is 5ms, 50ms and 1000ms respectively, and is used together with the IC card controller. Transmission distance ≤ 5m, powered by internal power supply.
- Alarm signal output: the output mode is CMOS level output, which is low level in normal time and high level in alarm time.
  - 1) battery undervoltage alarm output: when the battery voltage is lower than 3.2V, BAT\_AL2 port outputs an alarm signal; When the battery voltage is lower than 3.1V, BAT\_AL1 port outputs an alarm signal.
  - 2) Over-flow Range Alarm Output HL: When the flow range exceeds the upper limit, HL outputs an alarm signal.
- 4~20mA standard analog signal output: 4 ~ 20mA analog signal corresponds to standard volume flow, range is set by upper and lower limits of standard temperature and pressure flow, lower limit corresponds to 4mA, and upper limit corresponds to 20mA. Transmission distance ≤ 200m, connection mode is two-wire system or three-wire system, and power supply voltage is 24VDC.
- Signal output of RS-485 interface: MODBUS protocol RTU mode, half duplex mode, baud rate 1200~9600 optional, see MODBUS communication protocol description for details. RS-485 communication can realize the following functions:
  - 1) Directly connect with the upper computer, which can remotely transmit the temperature, pressure, standard volume flow and total volume of the measured medium, total volume of working conditions, relevant parameters of the instrument, fault codes, operation status and real-time data, etc.
  - 2) It can be used together with a special signal acquisition instrument and can form a remote data acquisition and monitoring system through GPRS/CDMA, Internet and telephone network. Data transmission is carried out through the network, the historical data and fault status of any flowmeter in the network are read, and relevant parameters of various flowmeters can be remotely set.
  - 3) SCADA system and DCS system can be formed together with PLC and RTU.
- Real-time database: flowmeter has real-time data storage function, including:
  - 1) the latest 2500 times of flow start-stop time and the corresponding standard cumulative flow value;
  - 2) Cumulative flow value at a certain moment in the latest 100 months;
  - 3) For the latest 5000 times of state data (including: time, temperature, pressure, instantaneous flow rate, working condition cumulative flow rate, standard cumulative flow rate, etc.), the recording time interval can be set, ranging from (1 min to 9999 min).

See the following table for the model specifications and basic parameters of flow meter:

**HGUF Ultrasonic Flow Meter (Wide Range) Table 1**

Diameter(mm)	Item	Initial flow(m3/h)	Flow range(m3/h)	Accuracy(m3/h)
25	HGUF-25	0.02	1~40	1%
32	HGUF-32	0.03	5-50	
40	HGUF-40	0.05	6~100	
50	HGUF-50	0.07	4~160	
80	HGUF-80	0.10	8-400	
100	HGUF-100	0.20	16~700	
150	HGUF-150	0.40	20~1400	
200	HGUF-200	0.50	36~2000	
250	HGUF-250	1	100-4000	
300	HGUF-300	1	100-6000	

**3. Typical Characteristic Curve**

Typical characteristic curve of flow meter is shown in fig. 4, y coordinate represents the basic error of the meter, and x coordinate represents the percentage of maximum flow.

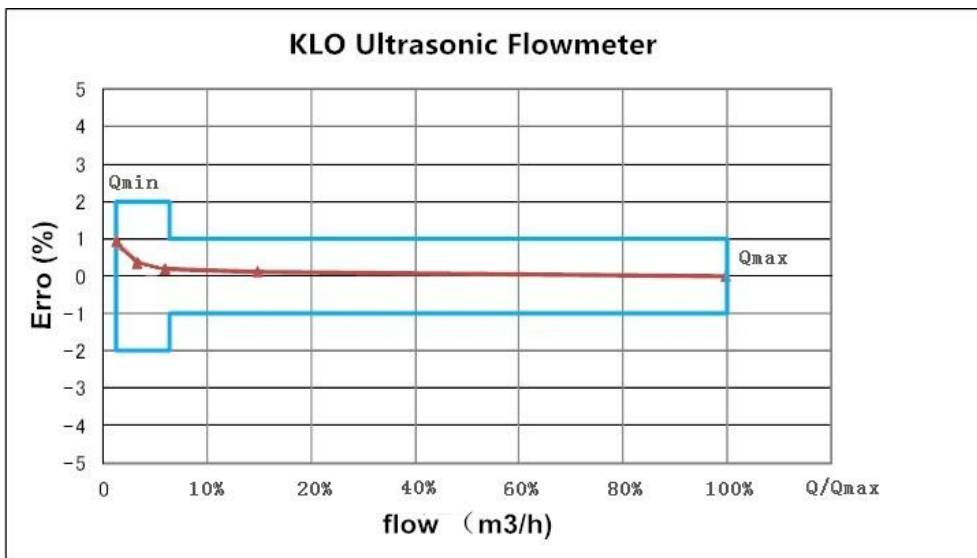

Fig. 4 typical characteristic curve



Overall Dimensions

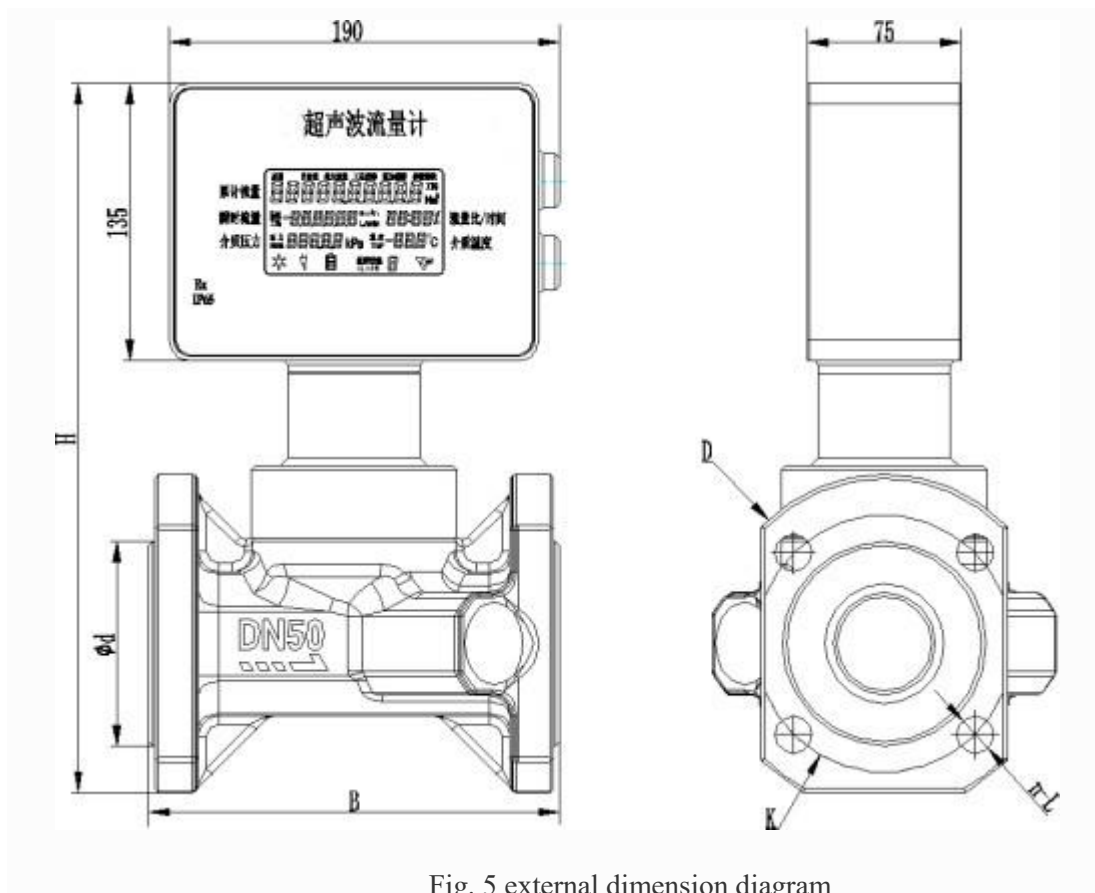

Fig. 5 external dimension diagram

Overall dimensions

Table 2

Item	Diameter DN(mm)	B	1.6MPa				
			H	D	d	K	n-L
HGUF-25	25(1")	200	325	115	65	85	4-Ø14
HGUF-40	40(1.5")	200	345	150	84	110	4-Ø18
HGUF-50	50(2")	200	365	165	99	125	4-Ø18
HGUF-80	80(3")	240	415	200	132	160	8-Ø18
HGUF-100	100(4")	300	435	220	156	180	8-Ø18
HGUF-150	150(6")	450	500	285	211	240	8-Ø22
HGUF-200	200(8")	600	540	340	266	295	12-Ø22
HGUF-250	250(10")	600	565	405	320	355	12-Ø26
HGUF-300	300(12")	600	590	460	375	410	12-Ø26