

TECHNOLOGY

HOLYKELL®

HR80G

LEVEL

• DATASHEET •

- 1. Pressure Measurement**
- 2. Level Measurement**
- 3. Temperature Measurement**
- 4. Flow Measurement**
- 5. Display & Control Instruments**
- 6. Wireless Monitoring System**
- 7. Velocity Measurement**

HR80G series

76-81GHz FMCW Radar Level Meters

Profiles

HR80G 76-81 FMCW radar (also called millimeter wave radar) level meters, as it uses a millimeter wave band with a higher frequency than Ku band radar, long-distance imaging and multi-spectral imaging in remote target detection and strong smoke and dust environments, it can detect smaller targets than microwave radar and achieve more precise positioning, it has higher resolution and stronger confidentiality.

It has a maximum measuring range of 120m and measuring accuracy of $\pm 2\text{mm}/\pm 1\text{mm}$ are optional, supporting 4-wire and 2-wire.

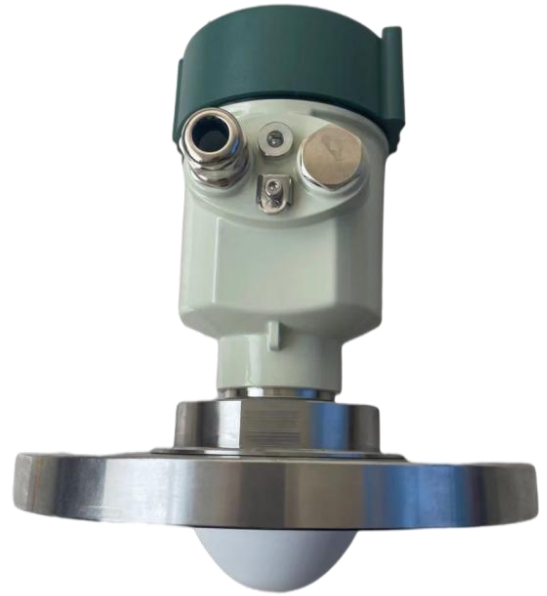

Features

- 76GHz-81GHz FM wave radar
- 5GHz ultra-large FM scanning frequency width, wide application
- Support standard HART, RS485/MODBUS bus protocol
- Support host computer setting software, tank side meter, etc. operation modes
- 24 V DC power supply
- Simple installation structure
- LCD display for local value reading
- Bluetooth function optional

Applications

- The electromagnetic wave emission angle of the product is less than 3° , which is suitable for narrow space or guided wave pipeline measurement;
- It can reach a measurement range of 120m, suitable for the measurement of large storage tanks;
- The measurement blind area is in the range of 7-8CM, suitable for small storage tanks;
- The measurement accuracy is suitable for high-precision measurement;
- It has a wealth of echo processing algorithms and data of various working conditions; it has unique advantages in storage tank applications that challenge other similar products in extremely harsh working conditions such as strong dust, steam, or special process storage tanks with stirring and heating rods.

Specifications

Parameter	HR80G
Frequency	76GHz-81GHz, 5GHz FMCW bandwidth
Measuring range	0.3~60m(For solids) 0.08~30m(For liquids) 0.6m~120m (For solids and liquids)
Measurement accuracy	±2mm / ±1mm
Beam angle	3°;6°
Dielectric constant range	≥2
Power supply	18-28 V DC;220VAC; 9-36V(By customized)
Communication	MODBUS; HART optional
Signal output	4-20mA or RS485
Field operation/ programming	128 × 64 dot matrix display / 4 buttons;PC software
Enclosure	Aluminum alloy, stainless steel
Antenna type	Lens antenna/anti-corrosive antenna / flange isolated by quartz
Process temperature/Humidity	-40~85°C/≤95%RH
Process pressure	-0.1~1.6MPa
Product Size	Ø100*270mm
Cable entry	M20*1.5
Recommended cables	AWG18 or 0.75mm ²
Protection class	IP67
Installation method	Thread or flange
Weight	Approx. 2.480Kg/2.995Kg(for reference only, the actual product shall prevail.)

Dimensions and Drawing

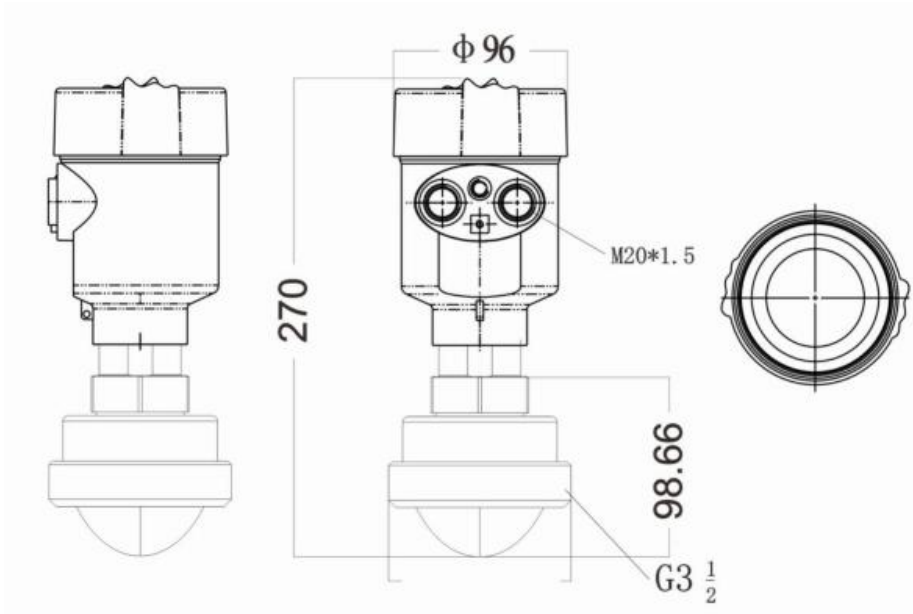

With 3° antenna beamwidth

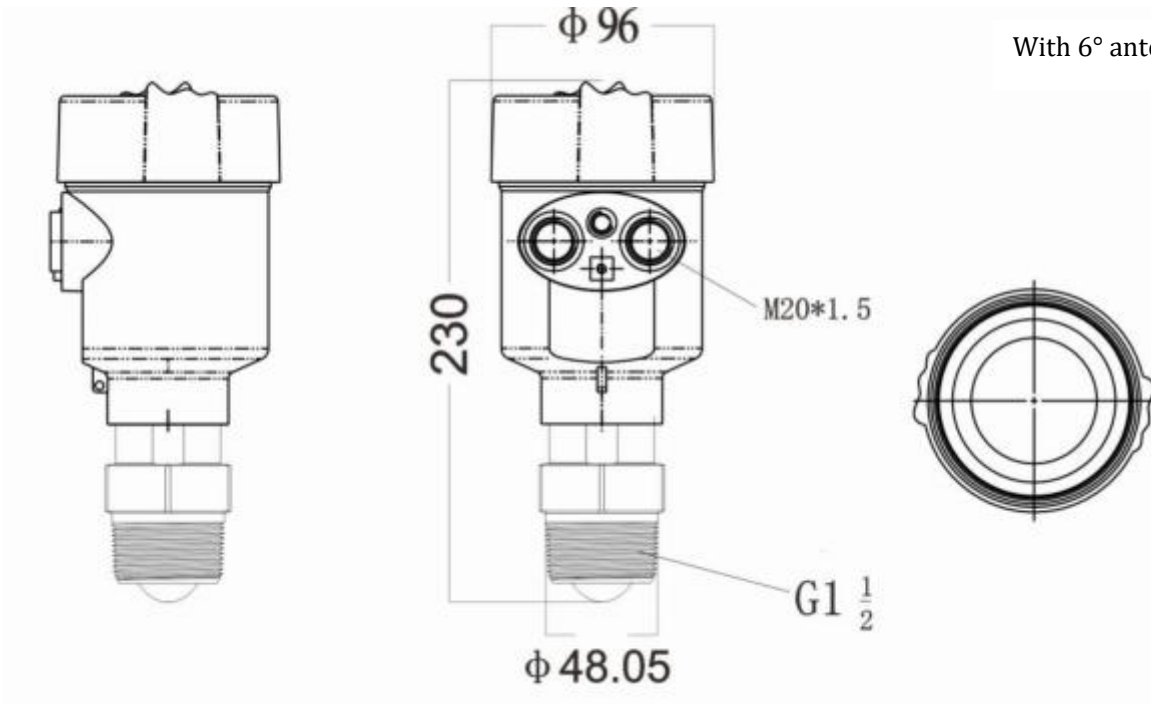

With 6° antenna beamwidth

Unit: mm

Dimensions of version with a high temperature flange

With 3° antenna beamwidth

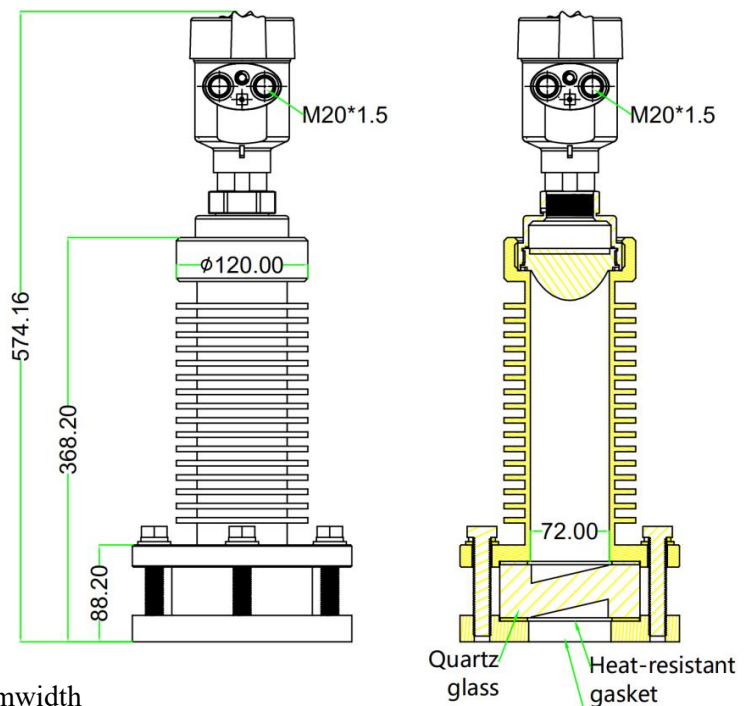

With 6° antenna beamwidth

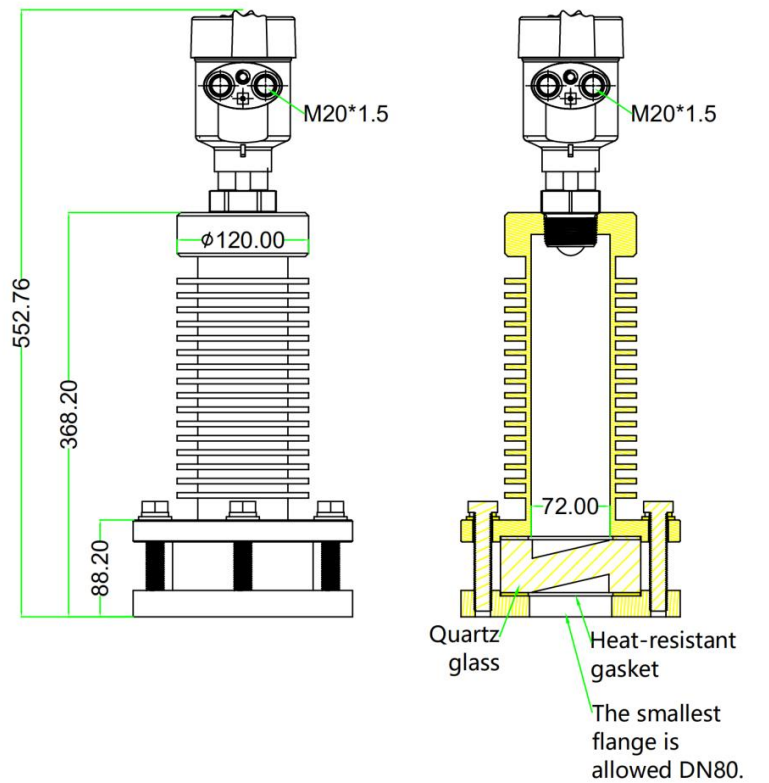

How to Order

80G conventional large lens	
Model	HR80G-A
Frequency range	76~81GHz
Application range	Slightly corrosive liquid, stirring, water vapor condensation
Measuring range	120 m
Signal output	4-20mA/HART (two-wire/four-wire) RS485/Modbus
Process connection	Flange, thread
Medium temperature	-30°C to +80 °C
Process pressure	-0.1 to 0.3Mpa
Measurement accuracy	±2mm / ±1mm
IP rating	IP67
Bluetooth	Optional function
Shell material	Aluminum casting/stainless steel



80G conventional large lens with universal blowing	
Model	HR80G-B
Frequency range	76~81GHz
Application range	Strong dust, solid, block, powder
Measuring range	120 m
Signal output	4-20mA/HART (two-wire/four-wire) RS485/Modbus
Process connection	Universal flange
Medium temperature	-40°C to +120 °C
Process pressure	-0.1 to 0.6Mpa
Measurement accuracy	±2mm / ±1mm
IP rating	IP67
Bluetooth	Optional function
Shell material	Aluminum casting/stainless steel



80G conventional small lens	
Model	HR80G-C
Frequency range	76~81GHz
Application range	Slightly corrosive liquid, stirring, condensation
Measuring range	120 m
Signal output	4-20mA/HART (two-wire/four-wire) RS485/Modbus
Process connection	Flange, thread
Medium temperature	-40°C to +120 °C
Process pressure	-0.1 to 0.3Mpa
Measurement accuracy	±2mm / ±1mm
IP rating	IP67
Bluetooth	Optional function
Shell material	Aluminum casting/stainless steel



80G anti-corrosive large flat lens	
Model	HR80G-D
Frequency range	76~81GHz
Application range	Strong corrosive liquid, stirring, water vapor, condensation
Measuring range	120 m
Signal output	4-20mA/HART (two-wire/four-wire) RS485/Modbus
Process connection	Flange, thread
Medium temperature	-40°C to +120 °C
Process pressure	-0.1 to 0.5Mpa
Measurement accuracy	±2mm / ±1mm
IP rating	IP67
Bluetooth	Optional function
Shell material	Aluminum casting/stainless steel



80G anti-corrosive large flat lens	
Model	HR80G-E
Frequency range	76~81GHz
Application range	High temperature environment, strong corrosive liquid, stirring, water vapor, condensation
Measuring range	120 m
Signal output	4-20mA/HART (two-wire/four-wire) RS485/Modbus
Process connection	Flange, thread
Medium temperature	-40°C to +200°C
Process pressure	-0.3 to 1.6Mpa
Measurement accuracy	±2mm / ±1mm
IP rating	IP67
Bluetooth	Optional function
Shell material	Aluminum casting/stainless steel



80G anti-corrosive small flat lens	
Model	HR80G-F
Frequency range	76~81GHz
Application range	strong corrosive liquid, stirring, water vapor, condensation
Measuring range	120 m
Signal output	4-20mA/HART (two-wire/four-wire) RS485/Modbus
Process connection	Flange, thread
Medium temperature	-40°C to +120 °C
Process pressure	-0.1 to 1.6Mpa
Measurement accuracy	±2mm / ±1mm
IP rating	IP67
Bluetooth	Optional function
Shell material	Aluminum casting/stainless steel



80G anti-corrosive flat lens	
Model	HR80G-G
Frequency range	76~81GHz
Application range	Strong corrosive liquid, stirring, water vapor, condensation
Measuring range	120 m
Signal output	4-20mA/HART (two-wire/four-wire) RS485/Modbus
Process connection	Flange
Medium temperature	-30°C to +80 °C
Process pressure	-0.1 to 0.3 Mpa
Measurement accuracy	±1mm
IP rating	IP67
Bluetooth	Optional function
Shell material	Aluminum casting/stainless steel



Product Selection Table

Note: Pls advise the following info.: Model No./Measuring range/ Signal output/
Process connection/Housing material/Flange material(if applicable)/Display.

	Example
Model No.	
1. HR80G-A 2. HR80G-B 3. HR80G-C 4. HR80G-D 5. HR80G-E 6. HR80G-F 7. HR80G-G	1
Measuring Range	
*** m(max 120m)	12
Signal Output	
3 4-20 mA+HART 5. RS485 Modbus	3
Process connection	
T. Thread F. Flange Y . Customized	F
Housing Material	
L. Cast Aluminum (typical) G. 304 Stainless steel S. 316L stainless steel	L
Flange Material	
G. 304 Stainless steel(typical) S. 316L stainless steel X. Not applicable	G
Display	
D. Double displays X. Standard display(typical)	X
Temperature	
A. Normal temperature B. By customized	A