

TECHNOLOGY

**HOLYKELL®**

**SP400**  
**LEVEL**  
• DATASHEET •

- 1. Pressure Measurement   2. Level Measurement   3. Temperature Measurement**  
**4. Flow Measurement   5. Display & Control Instruments**  
**6. Wireless Monitoring System   7. Velocity Measurement**

## Magnetostrictive Liquid Level Meter For Oil Depot

Magnetostrictive Liquid Level Meter (Tank gauging system) for oil depot produced by HOLYKELL consists of Flexible Hose Probe and Touch Control Console.

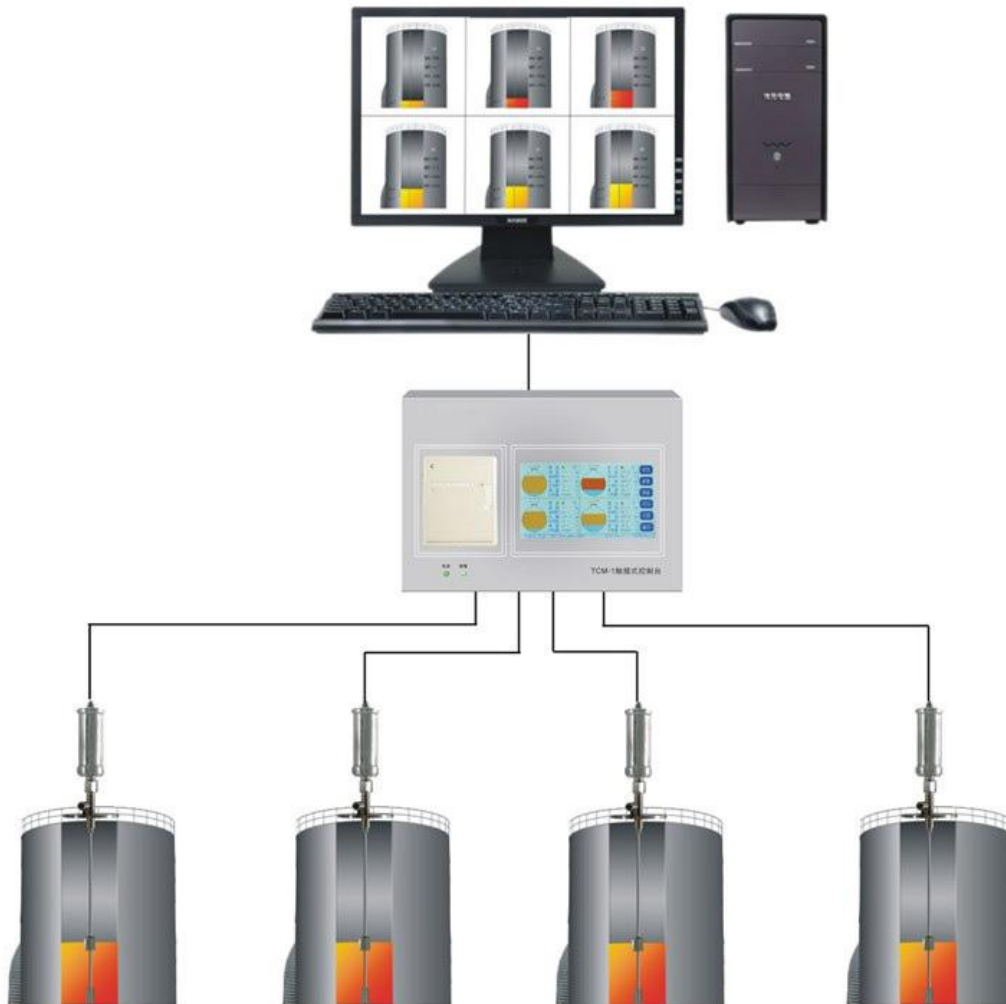

SP400 Probe + TCM-1 or -2 Smart Console

1. Industrial design, long service life, fast in running.
2. Information are stored in memory for future inquiry.
3. With an embedded printer(optional) it can print inventory reports, delivery reports, leak reports and shift reports
4. It can monitor up to Max 12 tanks and display dynamically the product level and water level with colored graphics in proportion.
5. After connected with Central Control System though internet, it can provide information for manager to manage the inventory, delivery and the sale of the product.

**SP400 Flexible Hose Magnetostrictive Probe**

- The probe consist of:  
Fully enclosed magnetostrictive probe.  
Electronic Pod using for data measuring and transforming.  
Floater made according to the product.
- Features:  
Safety: safe certificate issued by PCEC  
Accuracy: level accuracy is  $\pm 1\text{mm}$   
Stability: strong anti-jamming ability
- Probe Performance



Item	SP400
Purpose	To measure Fuel, Water and Other Liquids level and temperature
Titles of medium	Gasoline, diesel, kerosene, ethanol , water etc.
State of medium	Liquid
Pressure range	-0.02Mpa~0.6Mpa
Temperature	-40°C to +70°C
Level Accuracy	$\pm 1\text{mm}$
Water Level Accuracy	$\pm 1\text{mm}$
Temperature Accuracy	$\pm 0.2^\circ\text{C}$
Height Resolution	0.023mm
Repeatability	$\pm 0.1\text{mm}$
Temperature Effect	Error<0.2mm
Vibration Effect	Error<0.5mm
Lowest Inactive Zone	2.5" floater-180mm
Lowest Water Inactive Zone	2.5" floater-25mm
Measured Variable	Product level, interface level and temperature of 5 sensors and average temperature
Probe Length	Rigid Rod: 500mm to 4000mm by customized Soft Rod: 2000mm to 15000mm by customized
Communication	RS485
Power Supply	24-26 V DC

## TCM-1 Touch Control Console



- It can monitor up to 12 tanks and monitor the delivery conditions, it also enjoys a static leak test function.
- It can display product level, water level, temperature, volume, ullage.
- It enjoys a tank tilt compensation function.
- It can display dynamically the change of product level and water level with graphics in proportion, it features a 7 inch colored touch-screen console panel, and each interface displays 4 graphics.
- It features an audible and visual alarm function with front panel.
- It comes with two RS-232 serial interface communication ports to connect with different brand Center Console.
- It enjoys a record function, all information are stored in memory for future queries
- There is an embedded printer in it to print inventory reports, delivery reports, leak reports and shift reports.
- It can calculate volume of product by multipoint, which can fully ensure the accuracy of volume of the product.
- After connected with Center Console though internet, it can provide information in long-distance for manager to arrange the inventory.
- It can monitor the oil pump according to the product level, which can avoid the product spilled and pump down..
- It can connect with flow-meter to display delivery information constantly.
- It can connect with GSM Mode for wireless and remote data transfer and display all level and temperature info on mobile phone with SMS. i.e. level data, temp data, time and date info, level and volume alarm data and so on.

<b>TCM-1 Touch Control Console</b>	
<b>Parameters</b>	
Power Supply Voltage	AC120~265V 50HZ
Environmental Temperature	-20°C to +60°C
Environmental Humidity	20%~85%
Display Screen	7 inch real colorful touch screen
Processor / Memory	High-speed embedded / ---
Hard Disk / CF	---
Printer	Embedded mini type printer
Safety Barrier	Power safety barrier, communication safety barrier
Power-off protection	---
Size	310x220x105 (mm)
<b>Functions</b>	
Display	English, Graph, Colored
System Language	English
Monitoring Capability	1 to 12 tanks optional
Relay	With 2 relays
Method of Communication	RS-485
Tank Inventory Report	Users can inquire and print inventory information at any moment.
User-defined product type supported	Available
Auto Delivery	Auto delivery monitoring, and reports are generated after delivery. Users can inquire and print reports.
Manual delivery	Click the “start delivery”, it will create delivery report
Product Mass Calculation	---
Print Function	User can print all kinds of reports
Network Function	Inquiring data in long-distance through internet.
Outside Ringer	Avoiding the product spilled.
System Update	It's convenient to update the software and hardware.
Control the Oil Pump	Avoiding the product spilled and pumpdown
Setup/Inquiry Parameter	Users can setup and inquiry the parameter about the tank, hardware, product type, alarm, date, tank volume table
Automatic Gauge	Display product level, water level, temperature, volume, ullage
Volume Table Edit	Data input via touch screen, enjoy the import and export function.
Volume Table Calibration	Use the method of HOLYKELL Volume Table Calibration to calibrate it.
Static Leak Detection Function	During the idle time of the gas station, user can do the leak detection for the thank.( Detection rate :0.38 L/H)
Dynamic Leak Detection Function	---
Alarm	Audible and visual alarm and inquiry function
Shift Exchange	Shift exchange function and create the report.
Interface	With two RS-232 serial interface communication ports
Wireless device (optional)	GSM Mode (2G)

**Guidelines Before Installation**

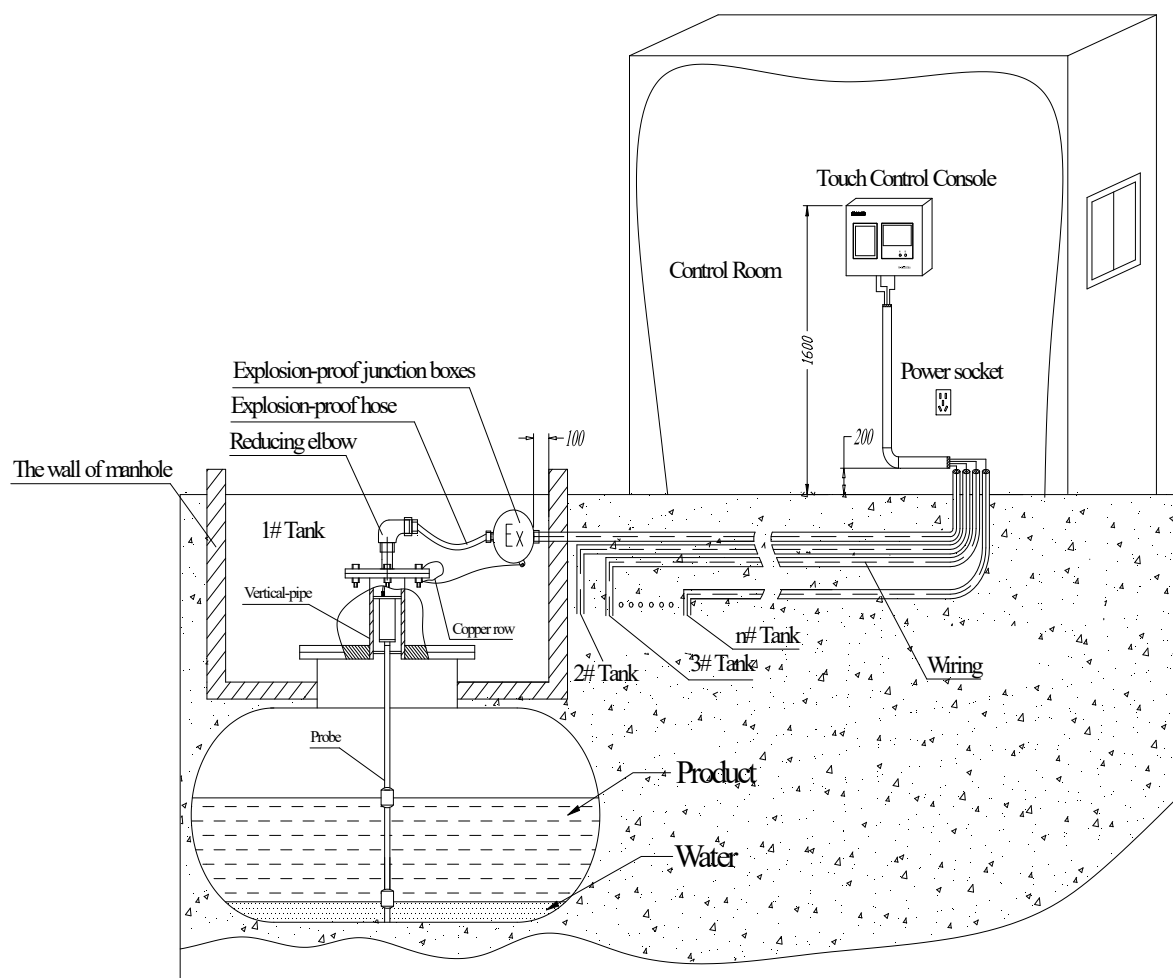

**Structural drawing of gas station**

**Guidelines before the liquid level meter installation.**

In order to ensure the installation successfully, you should make preparations as follows,

1. Welding the vertical-pipe and blind plate on the manhole cover of the tank (As shown in Figure 1.)
2. Cable wiring (As shown in Figure2.)
3. Renovation of the control room (As shown in Figure3.)

**Working standard**

1. Far away from the tank farm and other unsafe area.
2. The Power Ground in control room should be reliable

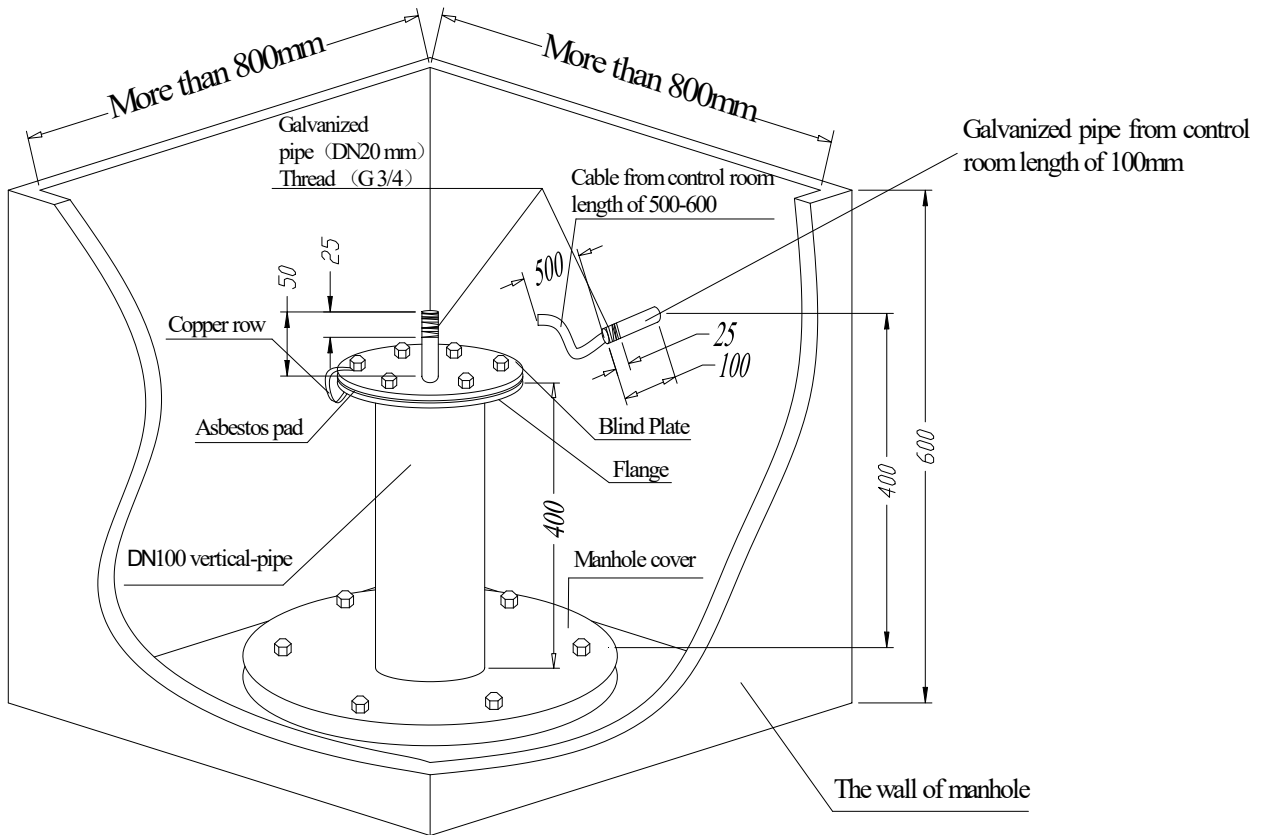

**Figure 1. Reformation of the wall of manhole**

**Reformation of the vertical-pipe**

- The DN100 vertical-pipe should be perpendicular to the manhole cover when welding. The part of the vertical-pipe entering the manhole cover should less than 50mm, and the pipe inside surface should be smoothly and no welding slag.
- In order to avoid the floater get stuck, there should no barrier from the welding part of the vertical-pie to the bottom of the tank.
- The part of the galvanized pipe exposed from the wall of manhole length of 100mm, its outer thread (G3/4) length of 25mm. The length of the communication cable exposed from the pipe is 500-600mm (as shown in Figure 1), and please ensure that there is no barrier within 150mm around it and 300mm ahead of it.
- Welding a galvanized pipe length of 50mm (it's outer thread G3/4 length of 25mm) on the center of the blind plate.
- Put asbestos pad between flange and blind plate, and cross them with copper row.



**Renovation of the control room**

- Position of Touch Control Console : As shown in Figure 3, drill two 60mm deep and  $\Phi 8$ mm diameter holes, the space between the holes is 270mm for TCM-1 and 250mm for TCM-2. Two bolts  $\Phi 8 \times 48$ , two screws ST4X60.
- Wiring: The communication cable channel should get the horizontal or vertical line, connect with elbow at the corner. An allowance for cable is 0.5m under the Control Console.
- Power Ground: Power Ground of Control Console and the socket should be reliable. Power Ground resistance should less than  $4\Omega$ , its material should be flexible cooper wire, has a diameter of  $\geq 4\text{mm}^2$ , the power socket should within 1.5m away from Control Console.
- Galvanized pipe: The galvanized pipe using for containing cable should above control room ground more than 200mm, and sealed the mouth of the pipe with plasticine.
- Wiring for outdoors ringer from the Touch Control Console to the ringer. An allowance for cable is 2m at the area of ringer installation, 0.5m under the Control Console.

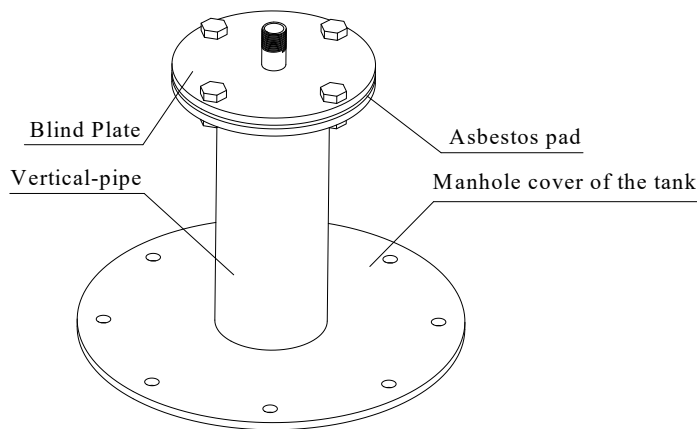

**Welding the vertical-pipe with blind plate**

**Working standard**

1. Try to welding the vertical-pipe on the line of the tank diameter.
2. The vertical-pipe should be perpendicular to the product level in the tank.
3. The pipe inside surface should be smoothly and no welding slag.
4. No barrier under the vertical-pie.

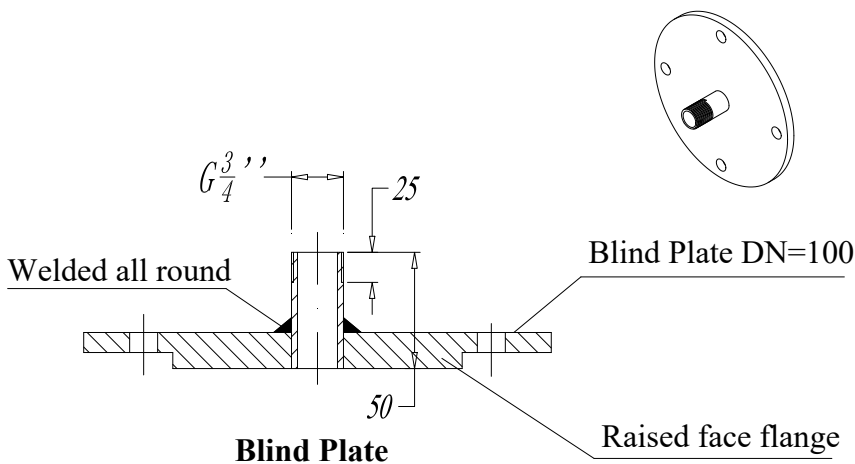

**Blind plate standard**

- 1.The installation holes on the blind plate should be math with the pipe flange.
- 2.The welding should be smoothly and no welding slag.
- 3.Paint antirust or aluminum paint on surface.

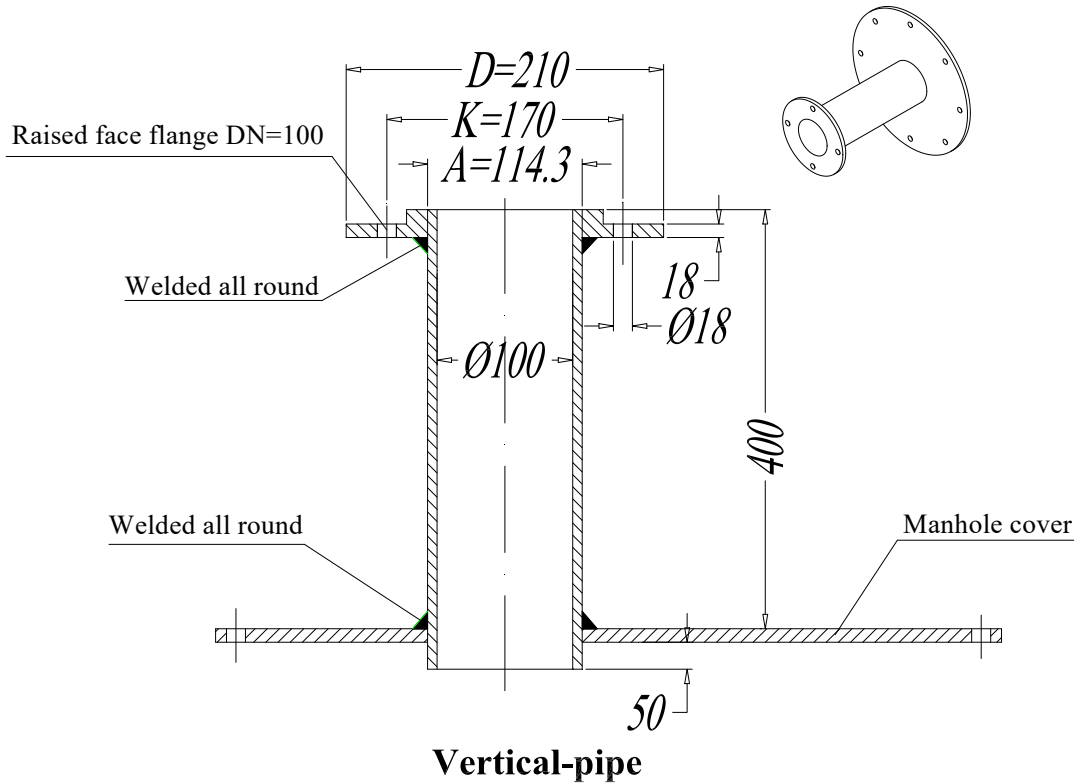

**Vertical-pipe standard**

- 1.The clearance between the vertical-pipe and flange should no be too large.
- 2.Try to welding the vertical-pipe on the line of the tank diameter.
- 3.The pipe inside and outside surface should be smoothly and no welding slag.
- 4.The vertical-pipe should be perpendicular to the product level in the tank.
- 5.No barrier under the vertical-pie.
- 6.Paint antirust or aluminum paint on surface.
- 7.The part of the vertical-pipe entering the manhole cover should less than 50mm

## Preparation Before Installation

The following preparation should be done before the liquid level meter installation.

1. Vertical-pipe
2. Blind plate
3. Wiring RVVP-4\*0.75 shielded cable from tank farm to control room, galvanized pipe on the outside of the shielded cable. The cable from tank farm to control room can not have a connector.
4. The part of the galvanized pipe exposed from the wall of manhole length about 100mm, its outer thread (G3/4) length of 25mm, using for connection with box.



**After level meter installation**

Make a hole on the center of the blind plate, welding vertical-pipe which inner diameter is 20mm, length of 50mm, galvanized pipe threaded at one end.

Vertical-pipe use for level meter installation, length of 400mm, inner diameter is 100mm.

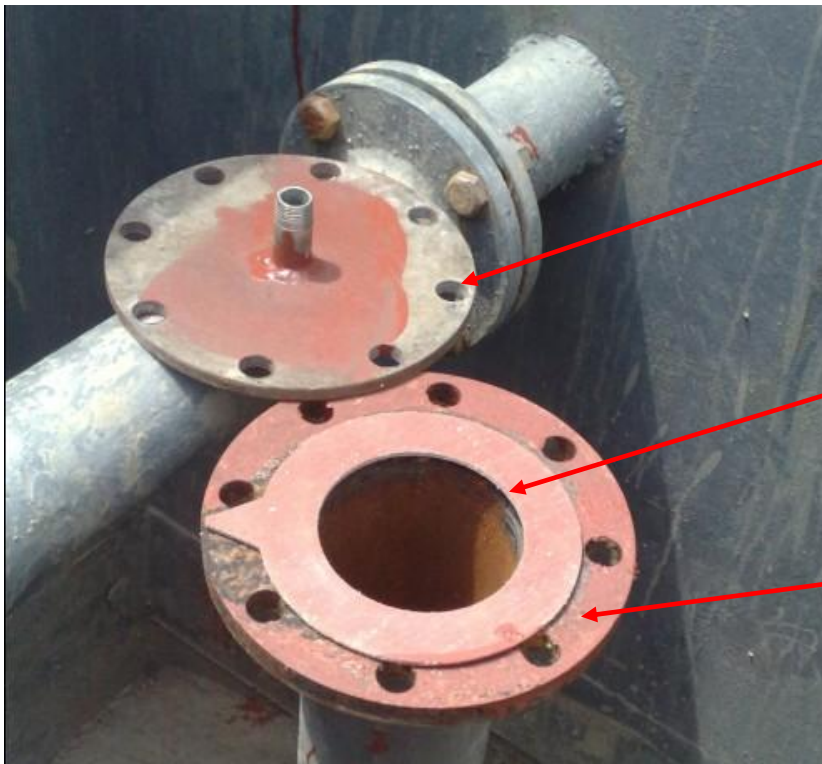
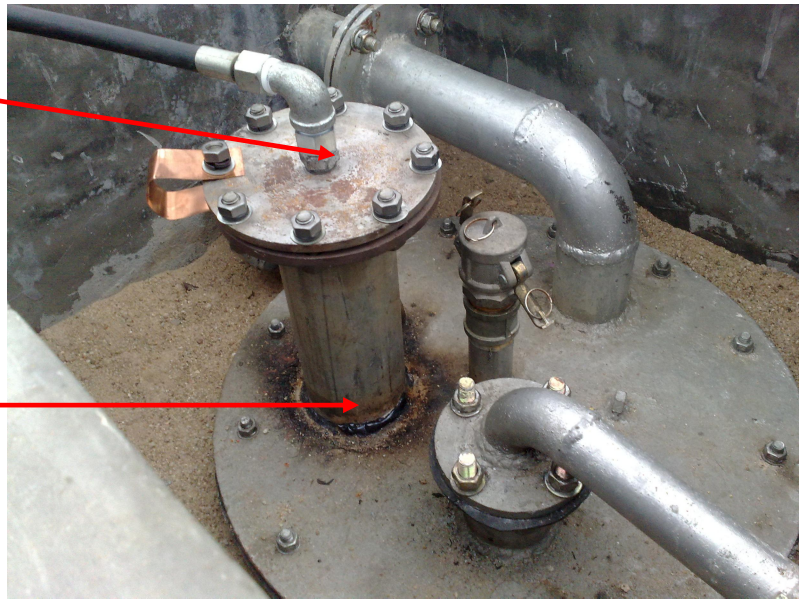

The diameter of the screw hole on the blind plate should be consistent with the hole on the top flange of the vertical-pipe.

Asbestos pad

Top flange of vertical-pipe.



Galvanized pipe on the outside of the shield cable

Blind plat

Vertical-pipe

2010/1/21 15:40

Manhole

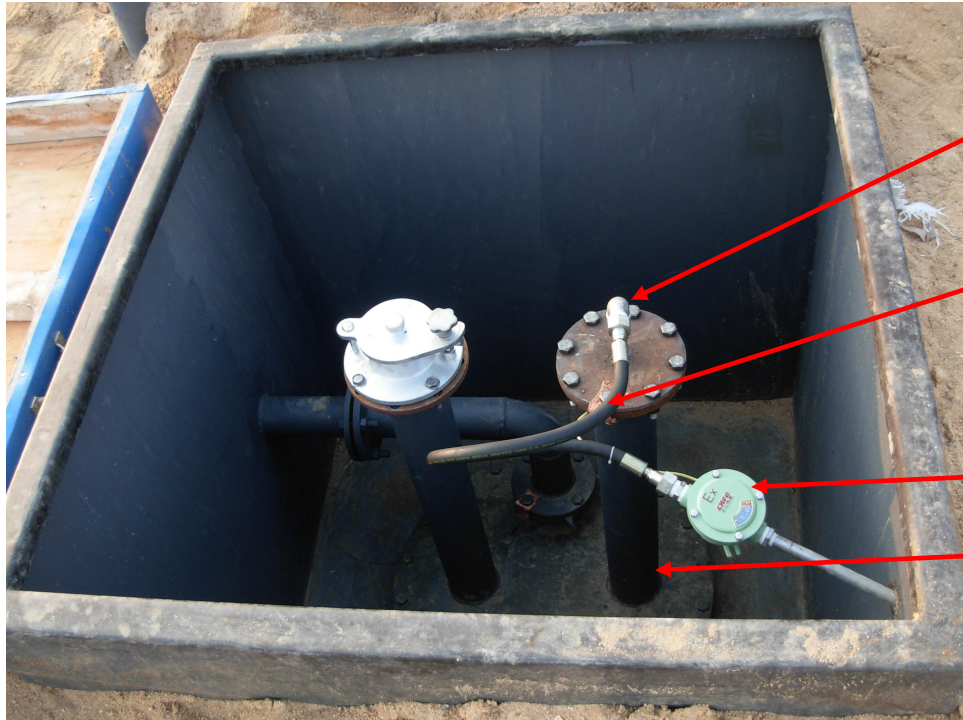

Reducing elbow

Hose

Box

Vertical-pipe

### Measuring method before installation

1.  $h_1$  : it's the height from the top surface of the manhole cover to the bottom of the tank
2.  $h_2$  : it's the height of vertical-pipe from the top surface of the vertical-pipe flange to the top surface of the manhole cover. Here is the size of vertical-pipe we recommended: 400mm above the manhole cover, 50mm under the cover.
3.  $D$  (diameter of the tank): it's the valid max inside diameter of the tank.
4.  $L$  (length of the tank): it's the valid max inside length of the tank.

Notes: If install the probe from the gauge hatch, you need to add a vertical-pipe at the top of the gauge hatch, and it's total height of the vertical-pipe and the gauge hatch is more than 400mm.

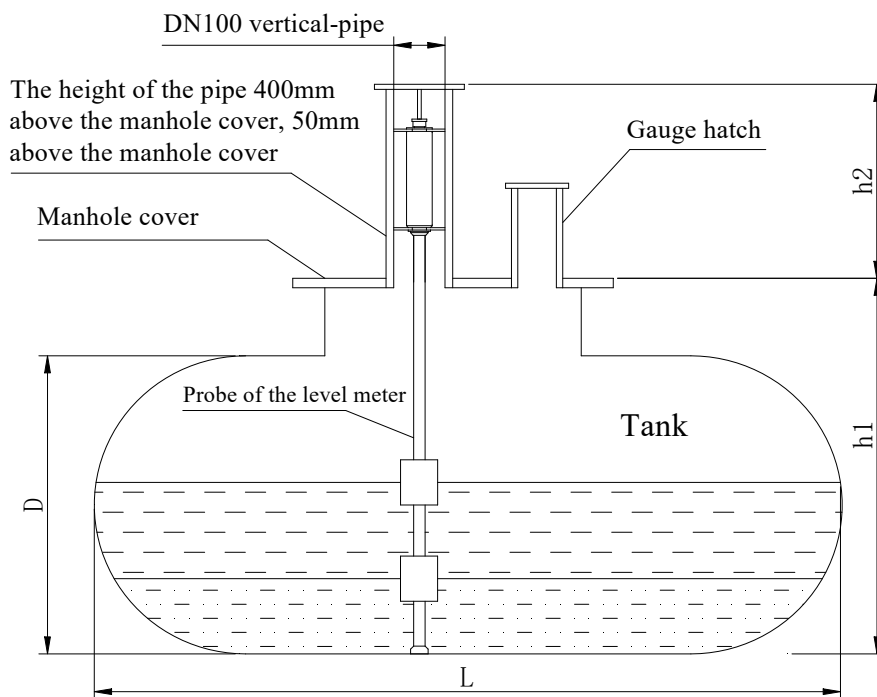

Tank No.	$h_1$ (mm)	$h_2$ (mm)	$D$ (mm)	$L$ (mm)	Product	Inside Diameter of Vertical-pipe (mm)
1# Tank						
2# Tank						
3# Tank						
4# Tank						
5# Tank						
6# Tank						
User Name :		Linkman:		Tel:	Fax:	Email:

Please fill in a form and mail this table to us.