

TECHNOLOGY

HOLYKELL®

UE3001
LEVEL
• DATASHEET •

- 1. Pressure Measurement 2. Level Measurement 3. Temperature Measurement**
4. Flow Measurement 5. Display & Control Instruments
6. Wireless Monitoring System 7. Velocity Measurement

UE3001

Ultrasonic Distance/Level Sensors

Profiles



5-15m



20-30m

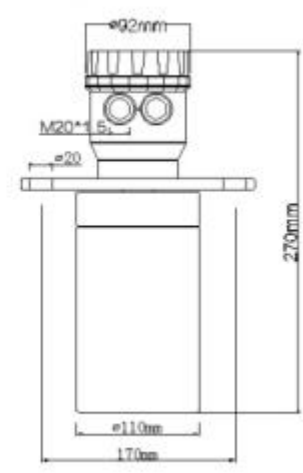
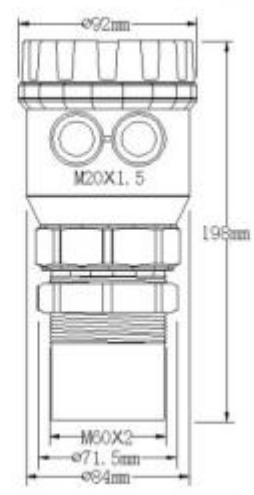

UE3001 Ultrasonic Level Sensor combines ultrasonic sensors, temperature sensors, ultrasonic servo circuit, transmission circuit and uses SMD components and ASIC which is developed together with the United States partner. All these features realize a concise and smart level transmitter. All gold-plated circuit boards, internal electromagnetic shielding and software digital filter are tested for (industrial) 48 hour under high and low temperature aging. It promises higher and long-term reliability. Shell is made of solid texture and good NLEPF acoustic characteristics of synthetic material. The body is shape sophisticated aesthetics, waterproof, dust proof, and can adapt to the most of working conditions on site. On liquid cans, the walls, or equipment arm movement, it's easy to install the UE3001 ultrasonic transmitter. There is no need of such tools as gongs nails, as long as there is a M60×2.0 gongs hole. A very quick and easy installation, maintenance can be realized.

Installation

		<ol style="list-style-type: none"> 1. Measure reference surface is the bottom line of sensor 2. Highest solid level cannot enter into the blind area 3. Level measurement should avoid the feeling hole, aim the smoother level surface 4. Better use sun/rain shade when mounting in out field 5. When mounting, sensor should be kept distance to the wall surface because of beam angle of ultrasonic wave. 6. When measuring the object level, the feeding hole should be avoided to prevent the ultrasound echo being interfered.
--	--	--

Features

1. Support M60*2 mm threaded into type installation and coil clamping type installation, the installation more convenient
2. Many model output optional customizable 4-20ma three-wire system, 1-5v, RS485 more customizable
3. Less than 9° Beam angle design ,Resolution 3mm, less than 200ms responsible time to make sure more accuracy
4. Wide range of application, Sealed high-temperature toxic volatile, strongly corrosive liquid medium level measurement of non-contact ultrasonic sensors
5. Housing adopts the NLEPE synthetic material IP66 waterproof, Anti-Skid, Anti-corrosion structure
6. High quality terminal blocks ,Excellent anti-jamming is strong, long term stability and durability

Specification

Parameter	UE3001		
Level Range	5, 7, 10, 12, 15m optional		
Blind area	5m range: 400mm; 5m~10m range: 500mm; 10m~15m range: 600mm		
Beam angle	<12°		
Accuracy	0.5%FS (at blind-fold drive away, 25 °C)		
Output	Analog signal 4-20mA; 1-5V; 0-5V; Load>300Ω; 0-5V; 0-10V	Digital signal RS485/RS232	Switch signal NPN Switch signal/ Relay (1 or 2 channels optional)
Power supply	DC24V/300mA		
Consumption	<1.5W		
Display	4 bits 8 segment LED display (LCD option available)		
Min. resolution	1mm		
Frequency	20 KHz~43.0KHz		
Working Temp	-20°C ~60°C		
Protection class	IP65 (default); IP67, IP68 (customized!)		
Housing	ABS/ Nylon		
Dimension	Φ92mm x 198mm x M60 (5m-15m range) Φ92mm x 270mm x DN80 nonstandard flange (20m-30m range)		
Installation	M60 x 2 or Φ61mm hole with gasket (5m-15m range) DN80 nonstandard flange (20m-30m range)		
Electrical connection	M20 x 1.5 (two units)		

Wiring Connection

1. Wiring diagram of current (voltage) output connecting with secondary instrument

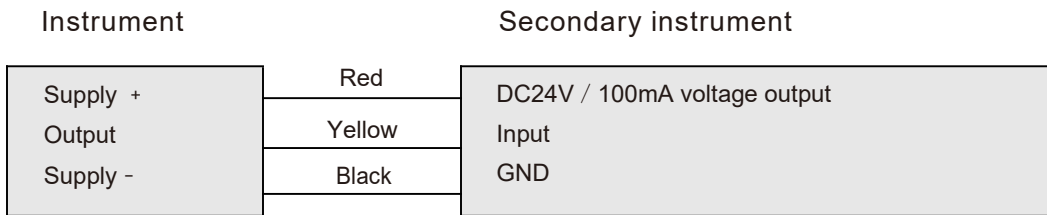

2. Wiring diagram of serial output connecting with PC

External power/ instrument/ 485 – 232/ PC

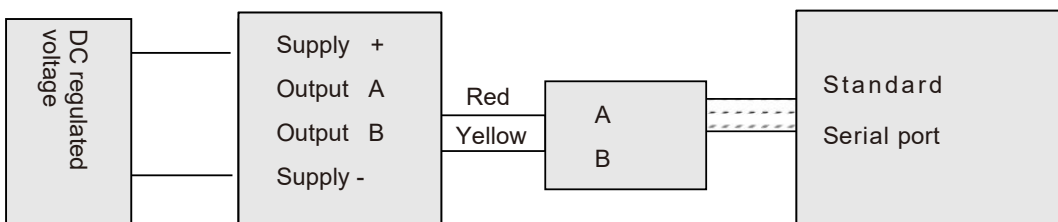

3. NPN output wiring diagram

Conventional relay

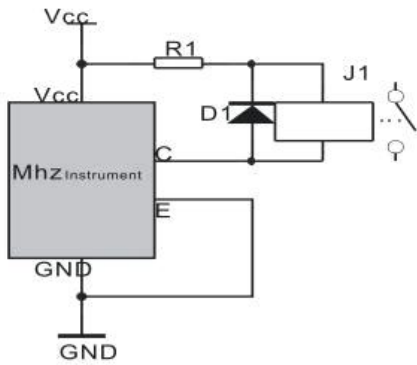

TTL output

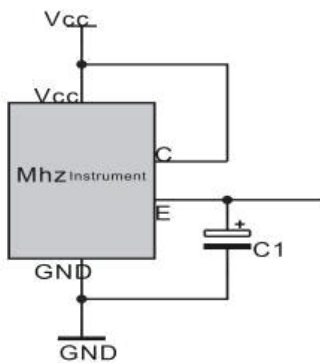
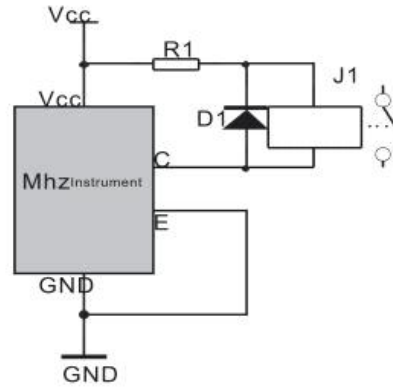

How To Order

Part Number Selection Table

UE3001	02	A	U1	A2	T1	002
Selection Type						
Range	01= 1 Meter 02= 2 Meters 15= 15 Meters					
Water Proof	A= IP66 B= IP65 C= IP67 D=IP68					
Power Supply	U1=DC12V/max 300mA U2=DC24V/max 300mA (UE3001) Ue=DC12V/max 300mA Ex					
Output	A2=Current Output (4-20mA 2 wires) A3=Current Output (4-20mA 3 wires) A4=Current Output (4-20mA 4 wires) N1/N2=Switch output (1 or 2 switches) J1 = Relay (Upper & Lower alarm) V1=Voltage output (0-5V) V2= Voltage output (1-5V) R=Digital RS485(MCU Protocol) X=By Customize					
Temperature	T= 0...50 °C T1= -10...60 °C T2= -20...70 °C					
Cable length	001= Cable 1m	002= Cable 2m	X= By Customized			

Application

