

TECHNOLOGY

HOLYKELL®

HR2000
LEVEL
• DATASHEET •

- 1. Pressure Measurement 2. Level Measurement 3. Temperature Measurement**
4. Flow Measurement 5. Display & Control Instruments
6. Wireless Monitoring System 7. Velocity Measurement

HR2000

80GHz High Accuracy Millimeter Wave Radar Level Sensor

Applications

- Water treatment
- Oil & gas industry
- Hydrological monitoring
- Rivers and channels
- Water/fuel tanks
- Chemical industry
- Petrochemical process storage tanks
- Pharmaceutical industry
- Food and beverage manufacturing
- Refining process vessels
- Sewage treatment
- Power generation
- Process control



Features

- High precision $\pm 10\text{mm}$, wide detection range
- Unique exterior design and compact size
- No-contact measurement adopted, without cleaning difficulty and maintenance
- Receiving little impact by condensation, rain, vapor, corrosion...
- Connection of host computer setting software, tank side meters...
- Wide power supply range with minimized power consumption
- Visualized PC interface
- High sensitivity, lightweight, easy integration
- Superior PC interaction performance
- Not affected by changes in dielectric constant & specific gravity of medium
- Easy to install with a bubble level design on the top
- No on-site calibration required

Profile

HR2000 is a high-precision ultra-low-power millimeter-wave radar level sensor developed and designed by Holykell. Its proprietary radar ranging algorithm and visualized PC interface enable high measurement accuracy, high sensitivity, easy integration, and superior PC interaction performance.

It uses non-contact technology, eliminating the need for physical contact with the measured substance, preventing contamination and minimizing maintenance requirements.

HR2000 can be used in various industries and applications, including liquids, distance, and even harsh environments such as chemicals, oil and gas, wastewater treatment, and food processing. Additionally, it can easily integrate with control and automation systems, allowing for seamless integration into industrial processes and enabling remote monitoring and control capabilities.

Specifications

Parameter	HR2000					
Working pressure	-1~3bar					
Measuring range	0.2-10m; 0.2-20m (For measuring range >10m, it supports 4-20mA+RS485 and regular power supply only, the low power consumption is not available)					
Measurement accuracy	Distance measuring accuracy: ±10mm(typical), ±5mm(customized)					
Analog 0-5V/0-10V/4-20mA accuracy	0.25%F.S(typical), 0.1%F.S(customized)					
FOV angle	8°					
Center frequency	80GHz					
Communication rate	Default 9600bit/s					
Scanning frequency	76-81GHz					
Power Supply	12-30 V DC(Regular type) 3.3-5.5V DC(Low voltage & low power consumption type)					
Signal output	12-30Vdc: 0-5V/0-10V/4-20mA+RS485 Modbus RTU 3.3-5.5V DC: RS485 Modbus RTU only					
Working temperature	-40~85°C					
Power consumption	Regular power supply		Low voltage & low power consumption		Low voltage	
	Min.	Max.	Min.	Max.	Min.	Max.
	0.72W (12V×0.06A)	1.2W (30V×0.04A)	0.067W	0.65W	0.5W	0.65W
Product Size	Ø131.5×76mm					
Protection class	IP67/IP68(3 bar) optional					
Material of wet parts	PVDF(Anti-corrosion type)					
Material of housing	PA6 nylon + Fiberglass					

Dimensions and Drawing

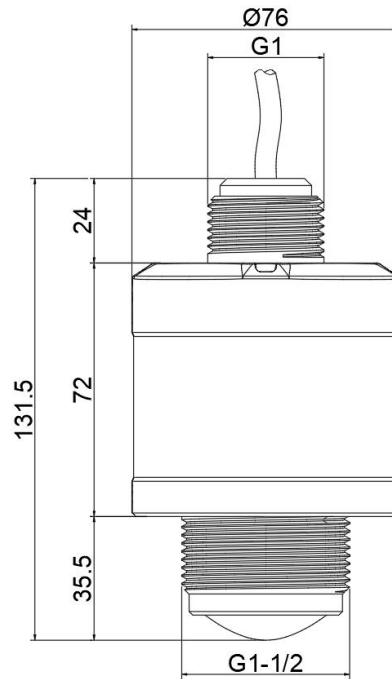

Unit: mm

Wiring

Pin No.	Definition	Wire Color
1	U+	Red
2	U-	Black
3	RS485-A	Green
4	RS485-B	Blue
5	0-10V/0-5V/4-20mA	Yellow

How to Order

1. Range Selection Table:

01	0.2~1	02	0.2~2	03	0.2~3	04	0.2~4	05	0.2~6	06	0.2~8	07	0.2~10
08	0.2~20m	X	By customized										

Kindly according to your application select suitable range code , Example: code 03 =3 .
 Unit of measure select on the Part Number Selection Table . Example: Code H=m H₂O, that's 3m H₂O

2. Part Number Selection Table:

2000 Selection Type	W	07	H	1	S10	4	001	1
Type	W=Water(Typical) F=Fuel							
Range	Range reference to range selection table code							
Level Units	H=m H ₂ O (Min: 0.2 m H ₂ O; Max:10 m H ₂ O) M=m Fuel (Min: 0.2 m fuel; Max:10 m fuel)							
Signal Output	1=RS485 Modbus RTU+4~20mA 2=RS485 Modbus RTU +0~5V 3=RS485 Modbus RTU+0~10V 4=RS485 Modbus RTU							
Power Supply	S10=12-30V DC	S56=3.3-5.5 V DC						
Accuracy	4=±10mm(Typical)	3=±5mm(By customized)						
Cable length	001= Cable 1m	002= Cable 2m	X= By Customized					
IP rating	1=IP67(Typical)	2=IP68(By customized)						